

NOTICE!!

These documents have been scanned!

Do not place un-scanned documents beneath this notice!

Do not remove this notice from this file!

GPO Jacket No. 560-102
Print Order 61540
Rise Business Services, LLC
Job=AZ15 5/17/2019



Box Number= AZ15063



Claim Begin-End: AMC402998-AMC403007

1 Initial Receipt



AZ15063-8

AMC402730-AMC403264

United States Department of the Interior
Bureau of Land Management
 LANDS/RECREATION & PLANNING
 ONE N CENTRAL AVE
 PHOENIX, AZ 85004 -2203
 Phone:

Receipt

No:

2247757

Transaction #: 2318855	ENTERED INTO COMPUTER <i>12-6-10 cm</i>
Date of Transaction: 11/17/2010	
CUSTOMER:	
CHARLES R BOWEN 2739 W JULIE LN YUMA, AZ 85365-8054 US	

LINE #	QTY	DESCRIPTION	REMARKS	UNIT PRICE	TOTAL
1	10.00	LOCATABLE MINERALS / MINING CLAIMS-NEW, UNADJUD, ONE OR MORE AUTH NOS / NEW MINING CLAIM LOCATION FEE \$34 CASES: AMC402998/\$34.00, AMC402999/\$34.00, AMC403000/\$34.00, AMC403001/\$34.00, AMC403002/\$34.00, AMC403003/\$34.00, AMC403004/\$34.00, AMC403005/\$34.00, AMC403006/\$34.00, AMC403007/\$34.00		- n/a -	340.00
2	10.00	LOCATABLE MINERALS / MINING CLAIMS-NEW, UNADJUD, ONE OR MORE AUTH NOS / NEW MINING CLAIM MAINT FEE \$140 CASES: AMC402998/\$140.00, AMC402999/\$140.00, AMC403000/\$140.00, AMC403001/\$140.00, AMC403002/\$140.00, AMC403003/\$140.00, AMC403004/\$140.00, AMC403005/\$140.00, AMC403006/\$140.00, AMC403007/\$140.00		- n/a -	1400.00
3	10.00	LOCATABLE MINERALS / MINING CLAIMS-NEW, UNADJUD, ONE OR MORE AUTH NOS / NEW MINING CLAIM PROCESSING FEE \$15 CASES: AMC402998/\$15.00, AMC402999/\$15.00, AMC403000/\$15.00, AMC403001/\$15.00, AMC403002/\$15.00, AMC403003/\$15.00, AMC403004/\$15.00, AMC403005/\$15.00, AMC403006/\$15.00, AMC403007/\$15.00		- n/a -	150.00
TOTAL:					\$1,890.00

PAYMENT INFORMATION			
1	AMOUNT:	1890.00	POSTMARKED: N/A
	TYPE:	CHECK	RECEIVED: 11/17/2010
	CHECK NO:	1950	
	NAME:	NT PRODUCTS INC BOX 18275 TUCSON AZ 85731 US	

REMARKS

This receipt was generated by the automated BLM Collections and Billing System and is a paper representation of a portion of the official electronic record contained therein.

NOTICE!!

These documents have been scanned!

Do not place un-scanned documents beneath this notice!

Do not remove this notice from this file!

GPO Jacket No. 560-102
Print Order 61540
Rise Business Services, LLC
Job=AZ15 5/17/2019



Box Number= AZ15063



Claim Begin-End: AMC402998-AMC403007

2 Correspondence



AZ15063-8

AMC402730-AMC403264

OFFICIAL COPIES /CF/ /SD READ/ /GROUP/ /SECTION/ /AUTHOR

ATC Manner
1/12/12
R
1-12-2012

JAN 12 2012

In Reply Refer To:

3800 (9310) AT

AMC402998, AMC403008, AMC403018



CERTIFIED MAIL - RETURN RECEIPT REQUESTED

NOTICE

Keith Bowen
1501 S. Cloverland Avenue
Tucson, Arizona 85711
CMRR # 7011 2970 0001 8020 7700

: AMC402998 – AMC403036

Charles R. Bowen
2739 Julie Lane
Yuma, Arizona 85365
CMRR# 7011 2970 0001 8020 7717

Raymond M. Deere
PO Box 95
Arivaca, Arizona 85601
CMRR# 7011 2970 0001 8020 7724

Eva Landry
765 W. Limberlost Drive #33
Tucson, Arizona 85705
CMRR# 7011 2970 0001 8020 7731

Additional Information Required

On August 25, 2011, we received four Maintenance Fee Waiver Certifications (small miner waivers) submitted together, which cover the 39 mining claims listed above. The waivers are from Keith Bowen, Charles Bowen, Raymond Deere and Eva Landry. We require further information in order to verify the validity of the small miner waivers.

Requested documents received
timely. AT

RECEIVED
BUREAU OF LAND MANAGEMENT
AZ STATE OFFICE
PHOENIX, ARIZONA
JUN 17 12 PM '02

UNITED STATES POSTAL SERVICE

PHOENIX AZ 850
JUN 12 PM '02



First-Class Mail
Postage & Fees Paid
USPS
Permit No. G-10

• Sender, please print your name, address, and ZIP+4 in this box •

BUREAU OF LAND MANAGEMENT
ARIZONA STATE OFFICE
ONE NORTH CENTRAL AVENUE
SUITE 800
PHOENIX, AZ 85004-2203

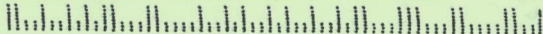

SENDER: COMPLETE THIS SECTION

- Complete items 1, 2, and 3. Also complete item 4 if Restricted Delivery is desired.
- Print your name and address on the reverse so that we can return the card to you.
- Attach this card to the back of the mailpiece, or on the front if space permits.

1. Article Addressed to:

Eva Landry
 765 W. Limberlost Drive #33
 Tucson, Arizona 85705
 9310 AT AMC402998,
 AMC403008, AMC403018

2. Article Number

(Transfer from service label)

7011 2970 0001 8020 7731

COMPLETE THIS SECTION ON DELIVERY

A. Signature

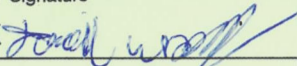
X  Agent AddresseeB. Received by (*Printed Name*)

David W. Wososz

C. Date of Delivery

D. Is delivery address different from item 1? Yes

If YES, enter delivery address below:

 No

3. Service Type

 Certified Mail Express Mail Registered Return Receipt for Merchandise Insured Mail C.O.D.4. Restricted Delivery? (*Extra Fee*) Yes

UNITED STATES POSTAL SERVICE

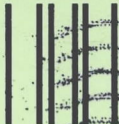

First-Class Mail
Postage & Fees Paid
USPS
Permit No. G-10

- Sender: Please print your name, address, and ZIP+4 in this box •

RECEIVED
BLM AZ STATE OFFICE
2012 JAN 23 PM 1:35
PHOENIX, ARIZONA

BUREAU OF LAND MANAGEMENT
ARIZONA STATE OFFICE
ONE NORTH CENTRAL AVENUE
SUITE 800
PHOENIX, AZ 85004-2203

SENDER: COMPLETE THIS SECTION

- Complete items 1, 2, and 3. Also complete item 4 if Restricted Delivery is desired.
- Print your name and address on the reverse so that we can return the card to you.
- Attach this card to the back of the mailpiece, or on the front if space permits.

1. Article Addressed to:

Raymond M. Deere
 PO Box 95
 Arivaca, Arizona 85601
 9310 AT AMC402998,
 AMC403008, AMC403018

2. Article Number

(Transfer from service label)

7011 2970 0001 8020 7724

COMPLETE THIS SECTION ON DELIVERY

A. Signature

X

Genara Deere

 Agent Addressee

B. Received by (Printed Name)

GENARA DEERE

C. Date of Delivery

D. Is delivery address different from item 1? Yes

If YES, enter delivery address below:

 NoARIZONA, AZ 85601
 JAN 20 2012

USPS

3. Service Type

 Certified Mail Express Mail Registered Return Receipt for Merchandise Insured Mail C.O.D.

4. Restricted Delivery? (Extra Fee)

 Yes

UNITED STATES POSTAL SERVICE



First-Class Mail
Postage & Fees Paid
USPS
Permit No. G-10

• Sender: Please print your name, address, and ZIP+4 in this box •

RECEIVED
BLM AZ STATE OFFICE

2012 JAN 19 PM 1:17

PHOENIX, ARIZONA

BUREAU OF LAND MANAGEMENT
ARIZONA STATE OFFICE
ONE NORTH CENTRAL AVENUE
SUITE 800
PHOENIX, AZ 85004-2203



SENDER: COMPLETE THIS SECTION

- Complete items 1, 2, and 3. Also complete item 4 if Restricted Delivery is desired.
- Print your name and address on the reverse so that we can return the card to you.
- Attach this card to the back of the mailpiece, or on the front if space permits.

1. Article Addressed to:

Charles R. Bowen
 2739 Julie Lane
 Yuma, Arizona 85365
 9310 AT AMC402998,
 AMC403008, AMC403018

COMPLETE THIS SECTION ON DELIVERY

A. Signature

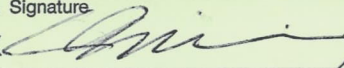
X

 Agent Addressee

B. Received by (Printed Name)

Charles Bowen

C. Date of Delivery

1-18-12

D. Is delivery address different from item 1?

 Yes

If YES, enter delivery address below:

 No

3. Service Type

 Certified Mail Express Mail Registered Return Receipt for Merchandise Insured Mail C.O.D.

4. Restricted Delivery? (Extra Fee)

 Yes

2. Article Number

(Transfer from service label)

7011 2970 0001 8020 7717

SENDER: COMPLETE THIS SECTION <ul style="list-style-type: none"> Complete items 1, 2, and 3. Also complete item 4 if Restricted Delivery is desired. Print your name and address on the reverse so that we can return the card to you. Attach this card to the back of the mailpiece, or on the front if space permits. 	COMPLETE THIS SECTION ON DELIVERY A. Signature <input checked="" type="checkbox"/> <i>David Worosz</i> <input type="checkbox"/> Agent <input type="checkbox"/> Addressee B. Received by (Printed Name) <input type="checkbox"/> C. Date of Delivery <i>David Worosz</i> D. Is delivery address different from item 1? <input type="checkbox"/> Yes If YES, enter delivery address below: <input type="checkbox"/> No
1. Article Addressed to: <div style="border: 1px solid black; padding: 5px;"> Eva Landry 765 W. Limberlost Drive #33 Tucson, Arizona 85705 9310 AT AMC402998, AMC403008, AMC403018 </div>	3. Service Type <input type="checkbox"/> Certified Mail <input type="checkbox"/> Express Mail <input type="checkbox"/> Registered <input type="checkbox"/> Return Receipt for Merchandise <input type="checkbox"/> Insured Mail <input type="checkbox"/> C.O.D.
2. Article Number (Transfer from service label) 7011 2970 0001 8020 7731	4. Restricted Delivery? (Extra Fee) <input type="checkbox"/> Yes
PS Form 3811, February 2004 Domestic Return Receipt 102595-02-M-1540	

SENDER: COMPLETE THIS SECTION <ul style="list-style-type: none"> Complete items 1, 2, and 3. Also complete item 4 if Restricted Delivery is desired. Print your name and address on the reverse so that we can return the card to you. Attach this card to the back of the mailpiece, or on the front if space permits. 	COMPLETE THIS SECTION ON DELIVERY A. Signature <input checked="" type="checkbox"/> <i>Genara Deere</i> <input type="checkbox"/> Agent <input type="checkbox"/> Addressee B. Received by (Printed Name) <input type="checkbox"/> C. Date of Delivery <i>GENARA DEERE</i> D. Is delivery address different from item 1? <input checked="" type="checkbox"/> Yes If YES, enter delivery address below: <input type="checkbox"/> No 
1. Article Addressed to: <div style="border: 1px solid black; padding: 5px;"> Raymond M. Deere PO Box 95 Arivaca, Arizona 85601 9310 AT AMC402998, AMC403008, AMC403018 </div>	3. Service Type <input type="checkbox"/> Certified Mail <input type="checkbox"/> Express Mail <input type="checkbox"/> Registered <input type="checkbox"/> Return Receipt for Merchandise <input type="checkbox"/> Insured Mail <input type="checkbox"/> C.O.D.
2. Article Number (Transfer from service label) 7011 2970 0001 8020 7724	4. Restricted Delivery? (Extra Fee) <input type="checkbox"/> Yes
PS Form 3811, February 2004 Domestic Return Receipt 102595-02-M-1540	

SENDER: COMPLETE THIS SECTION <ul style="list-style-type: none"> Complete items 1, 2, and 3. Also complete item 4 if Restricted Delivery is desired. Print your name and address on the reverse so that we can return the card to you. Attach this card to the back of the mailpiece, or on the front if space permits. 	COMPLETE THIS SECTION ON DELIVERY A. Signature <input checked="" type="checkbox"/> <i>Charles Bowen</i> <input type="checkbox"/> Agent <input checked="" type="checkbox"/> Addressee B. Received by (Printed Name) <input type="checkbox"/> C. Date of Delivery <i>Charles Bowen</i> 1-18-12 D. Is delivery address different from item 1? <input type="checkbox"/> Yes If YES, enter delivery address below: <input type="checkbox"/> No
1. Article Addressed to: <div style="border: 1px solid black; padding: 5px;"> Charles R. Bowen 2739 Julie Lane Yuma, Arizona 85365 9310 AT AMC402998, AMC403008, AMC403018 </div>	3. Service Type <input type="checkbox"/> Certified Mail <input type="checkbox"/> Express Mail <input type="checkbox"/> Registered <input type="checkbox"/> Return Receipt for Merchandise <input type="checkbox"/> Insured Mail <input type="checkbox"/> C.O.D.
2. Article Number (Transfer from service label) 7011 2970 0001 8020 7717	4. Restricted Delivery? (Extra Fee) <input type="checkbox"/> Yes
PS Form 3811, February 2004 Domestic Return Receipt 102595-02-M-1540	

RECEIVED
BLM AZ STATE OFFICE
2012 JAN 12 PM 3 L
UNITED STATES

POSTAL SERVICE
PHOENIX, AZ 850

First-Class Mail
Postage & Fees Paid
USPS
Permit No. G-10

• Sender: Please print your name, address, and ZIP+4 in this box •

BUREAU OF LAND MANAGEMENT
ARIZONA STATE OFFICE
ONE NORTH CENTRAL AVENUE
SUITE 800
PHOENIX, AZ 85004-2203

RECEIVED
BLM AZ STATE OFFICE
2012 JAN 23 PM 1: 35
PHOENIX, ARIZONA
UNITED STATES POSTAL SERVICE

First-Class Mail
Postage & Fees Paid
USPS
Permit No. G-10

• Sender: Please print your name, address, and ZIP+4 in this box •

BUREAU OF LAND MANAGEMENT
ARIZONA STATE OFFICE
ONE NORTH CENTRAL AVENUE
SUITE 800
PHOENIX, AZ 85004-2203

RECEIVED
BLM AZ STATE OFFICE
2012 JAN 19 PM 1: 17
PHOENIX, ARIZONA
UNITED STATES POSTAL SERVICE

First-Class Mail
Postage & Fees Paid
USPS
Permit No. G-10

• Sender: Please print your name, address, and ZIP+4 in this box •

BUREAU OF LAND MANAGEMENT
ARIZONA STATE OFFICE
ONE NORTH CENTRAL AVENUE
SUITE 800
PHOENIX, AZ 85004-2203

All 39 of these mining claims were filed at the same time, 10 in the name of Charles Bowen, 10 in the name of Raymond Deere, and 19 in the name of Keith Bowen. All of the location notices were filled out and signed by Keith Bowen. All of the new claim fees were paid by NT Products, Inc., a company owned by Charles Bowen. Thirty-one of the claims are named "NYI" followed by a number ranging from 1 to 37, which are interspersed between the various owners.

On August 15, 2011, right before the annual assessment was due, Keith Bowen transferred nine of the claims located in his name to Eva Landry. All four of the waiver documents were completed in the same handwriting and filed together. On December 13, 2011, we received five Affidavits of Labor for these 39 claims. All Affidavits were received together, all completed by Keith Bowen and all fees were paid for by Keith Bowen.

All of the above facts point to the fact that these 39 mining claims are definitely related and appear to be controlled by Keith Bowen, or at the very least, under common control of these four claimants. To qualify for a small miner waiver, **you and all related parties** must hold no more than a total of 10 mining claims or sites nationwide. 43 C.F.R. 3835.1(b) and 3835.11(a)(1). **"Related party means** a) the spouse and dependent children of the claimant as defined in section 152 of the Internal Revenue Code of 1986 [26 U.S.C. section 152]; or, b) **a person who controls, is controlled by, or is under common control with the claimant."** **"Control means actual control, legal control, or the power to exercise control, through or by common directors, officers, stockholders, a voting trust, or a holding company or Investment Company, or any other means."** 43 C.F.R. 3830.5.

By signing the small miner waiver, you certified that you and all related parties own ten or fewer mining claims, mill, or tunnel sites nationwide. Filing a small miner waiver that you do not qualify for in order to avoid paying the annual maintenance fee constitutes fraud. As stated under #6 of the waiver, "The undersigned understand and acknowledge that pursuant to 43 U.S.C. 1212 and 18 U.S.C. 1001, the filing or recording of a false, fictitious, or fraudulent document with the Bureau of Land Management (BLM) may result in a fine of up to \$250,000, a prison term not to exceed five years, or both.

If, after reviewing the above, you believe that you qualify for a small miner waiver, each mining claimant listed above must provide to BLM a notarized statement certifying that they are solely and independently in control of the claims listed in their name and that these claims are in no way under common control with the other claims listed here. Please also verify the relationship of these individuals to each other. On each document, Keith Bowen lists a different address, however on the Affidavits of Labor, he lists his address as being the same as Eva Landry.

Please provide the documents requested within 30 days of receipt of this letter. If we do not receive the requested information the small miner waivers will be denied and the claims will be forfeited.

If you have questions regarding this Notice, please contact Amy Thrower at 602-417-9334.
Please include your AMC serial number(s) on all correspondence.

Rebecca Heick
Group Administrator
Lands and Minerals

Athrower:lm:011212

NOTICE!!

These documents have been scanned!

Do not place un-scanned documents beneath this notice!

Do not remove this notice from this file!

GPO Jacket No. 560-102
Print Order 61540
Rise Business Services, LLC
Job=AZ15 5/17/2019



Box Number= AZ15063



Claim Begin-End: AMC402998-AMC403007

3 Transfers



AZ15063-8

AMC402730-AMC403264

**NO
DOCUMENTS
FOUND**

NO DOCUMENTS FOUND
NO DOCUMENTS FOUND

NOTICE!!

These documents have been scanned!

Do not place un-scanned documents beneath this notice!

Do not remove this notice from this file!

GPO Jacket No. 560-102
Print Order 61540
Rise Business Services, LLC
Job=AZ15 5/17/2019



Box Number= AZ15063



Claim Begin-End: AMC402998-AMC403007

4 Miscellaneous



AZ15063-8

AMC402730-AMC403264

**NO
DOCUMENTS
FOUND**

NO DOCUMENTS FOUND
NO DOCUMENTS FOUND

NOTICE!!

These documents have been scanned!

Do not place un-scanned documents beneath this notice!

Do not remove this notice from this file!

GPO Jacket No. 560-102
Print Order 61540
Rise Business Services, LLC
Job=AZ15 5/17/2019



Box Number= AZ15063



Claim Begin-End: AMC402998-AMC403007

5 Annual Filings



AZ15063-8

AMC402730-AMC403264



W
 KEITH BOWEN
 1025 S KROEGER LN
 TUCSON AZ 85745

E-mail address: hardrockm@outlook.com

AFFIDAVIT OF PERFORMANCE OF ANNUAL WORK

1. State of Arizona, County of Pima ss:
 2. I (Name) Keith H. Bowen
 3. Reside at (Address) 1025 S Kroeger Ln

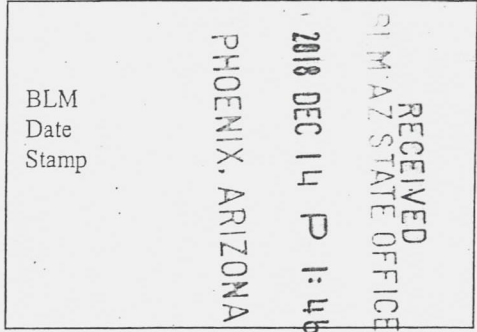

City Tucson County Pima

State AZ Zip 85745 being duly sworn, depose and say that I am a citizen of the United States, more than eighteen years of age, and that all of the facts set forth in this affidavit, subject to the provisions and penalties of 18 U.S.C. 1001 pertaining to the filing of false, fictitious, or fraudulent statements with the United States, are true and correct according to the best of my knowledge, information and belief.

4. Owner's name and address (If not shown in Items 1-3 above). Charles R Bowen
2739 W Julie Ln, Yuma, AZ, 85365

5. That I am personally acquainted with the mining claim(s). The work and improvements were made by and at the expense of the owner(s) of said claim(s). Said contiguous group of claims, listed on this document, are situated in the

Log Coujars (optional) Mining District; Pima County, Arizona.

Line No.	AMC NUMBER	CLAIM/SITE NAME	COUNTY RECORDER DATA (If available)	TWP	RNG	SEC
1	402998	Good Enough E	D13916 P 893	20S	10E	31
2	402999	Good Enough W	D13916 P 895	20S	10E	31
3	403000	NY1-10	D13916 P 931	21S	10E	5
4	403001	NY1-20	D13916 P 947	21S	10E	5
5	403002	NY1-25	D13916 P 951	21S	10E	5
6	403003	NY1-26	D13916 P 953	21S	10E	5

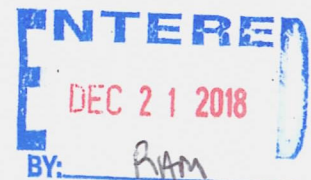

2

RECEIVED
PIMA AZ STATE OFFICE
2018 DEC 14 P 1:46
PHOENIX, ARIZONA

BLM
Date
Stamp

7	403004	NY1-27	D13916 P 955	215	10E	6
8	403005	NY1-28	D13916 P 957	215	10E	6
9	403006	NY1-29	D13916 P 959	215	10E	6
10	403007	NY1-35	D13916 P 961	215	10E	5

6. That between the dates starting at 12 o'clock noon on September 1, 20 17 and ending at 12 o'clock noon on September 1, 20 18 at least \$ 2000.00 dollars worth of work and improvements were done and performed upon said claim(s) or upon one or more of a contiguous group of claims for the benefit of all, wholly or partly outside of a contiguous group of claims for the benefit of all, not including the location work.

7. That the following persons were employed to perform the work and improvements described herein: SELF, Charles Bowa, Tom Parrish

8. That the work and improvements performed were: Fencing shafts, maintaining road, maintaining monuments, sampling, metallurgical testing

9. Dated: 11-8-18 Signature: [Signature]

SUBSCRIBED AND SWORN TO before me, a Notary Public, this 8th day of November 20 18.

By: [Signature]

Notary Public Jesus Duarte

My Commission Expires July 25, 2022

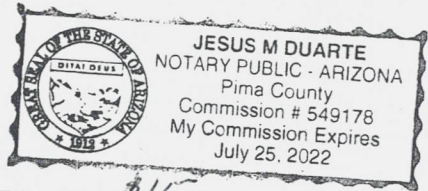

Bureau of Land Management
Arizona State Office
www.blm.gov/az

No. of Claims: 10 x \$10 = \$150
 Check No.: cash Init. [Init]
 Receipt No.: 4334518
 For BLM Use Only

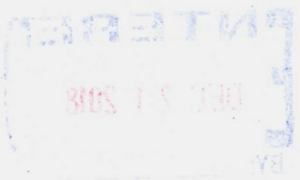



W

KEITH BOWEN
1025 S KROEGER LN
TUCSON AZ 85745

AFFIDAVIT OF PERFORMANCE OF ANNUAL WORK

1. State of Arizona, County of Pima ss:
2. I (Name) Keith H. Bowen
3. Reside at (Address) 1025 S Kroeger Ln
City Tucson County Pima

RECEIVED
PIMA STATE OFFICE
2018 DEC 14 P 1:47
PHOENIX, ARIZONA

State AZ Zip 85745 being duly sworn, depose and say that I am a citizen of the United States, more than eighteen years of age, and that all of the facts set forth in this affidavit, subject to the provisions and penalties of 18 U.S.C. 1001 pertaining to the filing of false, fictitious, or fraudulent statements with the United States, are true and correct according to the best of my knowledge, information and belief.

4. Owner's name and address (If not shown in Items 1-3 above). Eva J. Landry
1025 S Kroeger Ln, Tucson, AZ 85745

5. That I am personally acquainted with the mining claim(s). The work and improvements were made by and at the expense of the owner(s) of said claim(s). Said contiguous group of claims, listed on this document, are situated in the

Los Guajros (optional) Mining District; Pima County, Arizona.

Line No.	AMC NUMBER	CLAIM/SITE NAME	COUNTY RECORDER DATA (If available)	TWP	RNG	SEC
1	403019	Brok Bone N	D13916 P919	21S	10E	8
2	403020	Brok Bone S	D13916 P 899	21S	10E	8
3	403025	NY1-11	D13916 P 933	21S	10E	5
4	403024	NY1-12	D 13916 P 935	21S	10E	5
5	403028	NY1-16	D 13916 P 915	21S	10E	8
6	403029	NY1-17	D 13916 P 917	21S	10E	8

RECEIVED
PIMA STATE OFFICE
2018 DEC 14 P 1:47
PHOENIX, ARIZONA

BLM
Date
Stamp

7	403030	NY1-18	D13916 P941	215	10E	8
8	403032	NY1-22	D13916 P949	215	10E	5
9	403033	NY1-23	D13916 P923	215	10E	8
10						

6. That between the dates starting at 12 o'clock noon on September 1, 20 17 and ending at 12 o'clock noon on September 1, 20 18 at least \$ 2000.00 dollars worth of work and improvements were done and performed upon said claim(s) or upon one or more of a contiguous group of claims for the benefit of all, wholly or partly outside of a contiguous group of claims for the benefit of all, not including the location work.

7. That the following persons were employed to perform the work and improvements described herein: SELF, Charles Bown, Tom Parrish

8. That the work and improvements performed were: SHORT Fencing, road maintenance, monument maintenance, sampling, Metallurgical Testing

9. Dated: 11-8-18 Signature: [Signature]

SUBSCRIBED AND SWORN TO before me, a Notary Public, this 8th day of November 2018

By: [Signature]

Notary Public Jesus Duarte

My Commission Expires July 25, 2022

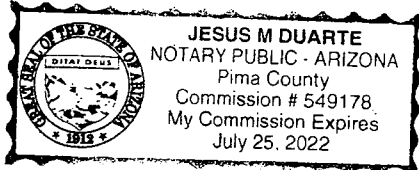

Bureau of Land Management
Arizona State Office
www.blm.gov/az

No. of Claims: 9 x \$~~15~~¹⁵ = \$135
 Check No.: CASH Init. EDC
 Receipt No.: 4334518
 For BLM Use Only



W
 KEITH BOWEN
 1025 S KROEGER LN
 TUCSON AZ 85745

E-mail address: ward@pima.gov OUTLOOK, com

AFFIDAVIT OF PERFORMANCE OF ANNUAL WORK

1. State of Arizona, County of Pima ss:
 2. I (Name) Keith H. Bowen
 3. Reside at (Address) 1025 S Kroeger Ln
 City Tucson County Pima

RECEIVED
 PIMA STATE OFFICE
 2018 DEC 14 P 1:46
 PHOENIX, ARIZONA
 BLM
 Date
 Stamp

State AZ Zip 85745 being duly sworn, depose and say that I am a citizen of the United States, more than eighteen years of age, and that all of the facts set forth in this affidavit, subject to the provisions and penalties of 18 U.S.C. 1001 pertaining to the filing of false, fictitious, or fraudulent statements with the United States, are true and correct according to the best of my knowledge, information and belief.
 4. Owner's name and address (if not shown in Items 1-3 above): SAME

5. That I am personally acquainted with the mining claim(s). The work and improvements were made by and at the expense of the owner(s) of said claim(s). Said contiguous group of claims, listed on this document, are situated in the Ward Buigas (optional) Mining District; Pima County, Arizona.

Line No.	AMC NUMBER	CLAIM/SITE NAME	COUNTY RECORDER DATA (If available)	TWP	RNG	SEC
1	403021	NY1-1	D13916 P901	21S	10E	4
2	403022	NY1-2	D13916 P903	21S	10E	4
3	403023	NY1-6	D13916 P907	21S	10E	5
4	403024	NY1-7	D13916 P909	21S	10E	5
5	403027	NY1-13	D13916 P913	21S	10E	5
6	403031	NY1-21	D13916 P921	21S	10E	5

RECEIVED
BLM AZ STATE OFFICE
2018 DEC 14 P 1:46
PHOENIX, ARIZONA

BLM
Date
Stamp

7	403018	Angelita	D18916 P 897	215	10E	8
8						
9						
10						

6. That between the dates starting at 12 o'clock noon on September 1, 20 17 and ending at 12 o'clock noon on September 1, 20 18 at least \$ 2000.00 dollars worth of work and improvements were done and performed upon said claim(s) or upon one or more of a contiguous group of claims for the benefit of all, wholly or partly outside of a contiguous group of claims for the benefit of all, not including the location work.

7. That the following persons were employed to perform the work and improvements described herein: SELF, Charles Bawa, Tom Parrish

8. That the work and improvements performed were: Fencing shorts, road maintenance, monument maintenance, sampling, metallurgical testing

9. Dated: 11-8-18 Signature: [Signature]

SUBSCRIBED AND SWORN TO before me, a Notary Public, this 8th day of November 20 18

By: [Signature]
Notary Public Jesus Duarte

My Commission Expires July 25, 2022

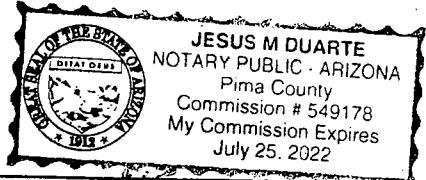

Bureau of Land Management
Arizona State Office
www.blm.gov/az

No. of Claims: 7 x \$15 = \$105
Check No.: CASH Init. CD
Receipt No.: 4334518
For BLM Use Only

When Recorded Return Docur to:

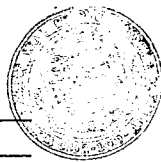

2018-07164

Page 1 of 2

Requested By: Keith Bowen

SUZANNE SAIHZ, RECORDER

SANTA CRUZ COUNTY, ARIZONA

11-09-2018 01:15 PM Recording Fee \$15.00

Check here is this is a change of address.

Telephone: 520-631-6523

E-mail address: handbook@outlook.com

AFFIDAVIT OF PERFORMANCE OF ANNUAL WORK

1. State of Arizona, County of Santa Cruz ss:

2. I (Name) Keith H. Bowen

3. Reside at (Address) 1025 S Kroeger Ln

City Tucson County Pima

RECEIVED
PIMA STATE OFFICE
2018 DEC 14 P 1:46
PHOENIX, ARIZONA
BLM
Date
Stamp

State AZ Zip 85745 being duly sworn, depose and say that I am a citizen of the United States, more than eighteen years of age, and that all of the facts set forth in this affidavit, subject to the provisions and penalties of 18 U.S.C. 1001 pertaining to the filing of false, fictitious, or fraudulent statements with the United States, are true and correct according to the best of my knowledge, information and belief.

4. Owner's name and address (If not shown in Items 1-3 above). SAME

5. That I am personally acquainted with the mining claim(s). The work and improvements were made by and at the expense of the owner(s) of said claim(s). Said contiguous group of claims, listed on this document, are situated in the

Oro Blanco (optional) Mining District; Santa Cruz County, Arizona.

Line No.	AMC NUMBER	CLAIM/SITE NAME	COUNTY RECORDER DATA (If available)	TWP	RNG	SEC
1	403034	ST Christopher #1	2010-09112	22S	10E	26
2	403035	" #2	2010-08113	22S	10E	26/35
3	403036	" #3	2010-08114	22S	10E	26
4						
5						
6						

2018-07184 11-09-2018 01:15 PM Page 2 of 2

RECEIVED
PIMA STATE OFFICE
PHOENIX, ARIZONA
2018 DEC 14 P 1:46
BLM
Date
Stamp

7					
8					
9					
10					

6. That between the dates starting at 12 o'clock noon on September 1, 20 17 and ending at 12 o'clock noon on September 1, 20 18 at least \$ 600.00 dollars worth of work and improvements were done and performed upon said claim(s) or upon one or more of a contiguous group of claims for the benefit of all, wholly or partly outside of a contiguous group of claims for the benefit of all, not including the location work.

7. That the following persons were employed to perform the work and improvements described herein: _____

SELF, Charles Bowe, 1 laborer

8. That the work and improvements performed were: FENCE SHEETS, road

MAINTENANCE, MONUMENT MAINTENANCE, sampling, metallurgical testing

9. Dated: 11-4-18 Signature: [Signature]

SUBSCRIBED AND SWORN TO before me, a Notary Public, this 8th day of November 2018.

By: [Signature]

Notary Public Jesus Duarte

My Commission Expires July 25, 2022

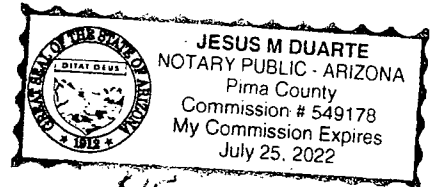

Bureau of Land Management
Arizona State Office
www.blm.gov/az

No. of Claims: 3 x \$~~15~~¹⁵ = \$45
 Check No.: cash Init. [Initials]
 Receipt No.: 4334518
 For BLM Use Only

Form: MCF108
Revised July 2014
Page 2 of 2

United States Department of the Interior
Bureau of Land Management
 DIV OF LANDS, MINRLS & ENERGY
 ONE N CENTRAL AVE
 PHOENIX, AZ 85004 -4427
 Phone: 602-417-9200

Receipt

No: 4334518

Transaction #: 4451252	
Date of Transaction: 12/14/2018	
CUSTOMER:	
	KEITH H BOWEN 1025 S KROEGER LN TUCSON, AZ 85745-3070 US

LINE #	QTY	DESCRIPTION	REMARKS	UNIT PRICE	TOTAL
1	1.00	LOCATABLE MINERALS / MINING CLAIMS- NOT NEW-UNADJUD, ONE AUTH NO. ONLY / MINING CLAIM MONEY RECEIVED CASES: AMC402998/\$435.00	2018 POL (29)	- n/a -	435.00
TOTAL:					\$435.00

PAYMENT INFORMATION			
1	AMOUNT:	435.00	POSTMARKED: N/A
	TYPE:	CASH	RECEIVED: 12/14/2018
	NAME:	BOWEN, KEITH H 1025 S KROEGER LN TUCSON AZ 85745-3070 US	

REMARKS

This receipt was generated by the automated BLM Collections and Billing System and is a paper representation of a portion of the official electronic record contained therein.

UNITED STATES
DEPARTMENT OF THE INTERIOR
BUREAU OF LAND MANAGEMENT

MAINTENANCE FEE WAIVER CERTIFICATION

FORM APPROVED
OMB NO. 1004-0114
Expires: January 31, 2020

SEE INSTRUCTIONS ON PAGE 2

1. This small miner waiver is filed for the assessment year beginning on September 1, 2018 and ending on September 1, 2019.
2. The undersigned and all related parties owned ten or fewer mining claims, mill, or tunnel sites located and maintained on Federal lands in the United States of America on September 1, 2018.
3. The undersigned have performed the assessment work required by law for each mining claim listed prior to filing this waiver and understand that by filing this form, the undersigned must file an affidavit of assessment work with the Bureau of Land Management (BLM) by the December 30th following the filing of this waiver.
4. The undersigned understand that if the assessment work obligation has not yet come due under 30 U.S.C. 28 (for those claims in their first assessment year only), a notice of intent to hold reciting this condition must be recorded by the December 30th following the filing of this waiver.
5. The undersigned understand that mill and tunnel sites may also be listed on this waiver and be waived from payment of the maintenance fee, and that a notice of intent to hold for these sites is required to be filed with the BLM by the December 30th following the filing of this waiver.
6. The undersigned understand and acknowledge that pursuant to 43 U.S.C. 1212 and 18 U.S.C. 1001, the filing or recording of a false, fictitious, or fraudulent document with the BLM may result in a fine of up to \$250,000, a prison term not to exceed five years, or both.
7. The mining claims, mill or tunnel sites for which this waiver from payment of the maintenance fees is requested are:

CLAIM OR SITE NAME	BLM RECORDATION SERIAL NUMBER
1. GOOD ENOUGH E	AMC 402998
2. GOOD ENOUGH W	AMC 402999
3. NY1-10	AMC 403000
4. NY1-20	AMC 403001
5. NY1-25	AMC 403002
6. NY1-26	AMC 403003
7. NY1-27	AMC 403004
8. NY1-28	AMC 403005
9. NY1-29	AMC 403006
10. NY1-35	AMC 403007

RECEIVED
 BLM AZ STATE OFFICE
 2018 AUG - 9 P 3:26
 PHOENIX, ARIZONA

The owner(s) (claimants) of the above mining claims and sites are:

10 ct CHARLES R. BOWEN

 (Owner's Name - Please Print)
 2739 W JULIE LN ✓

 (Owner's Mailing Address)

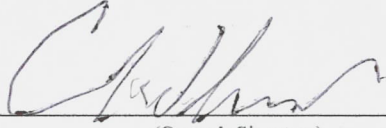

 (Owner's Signature)
 YUMA AZ 85365

 (City) (State) (Zip Code)

 (Owner's Name - Please Print)

 (Owner's Mailing Address)

AC483
 ENTERED SEP 05 2018
PB _____
 (City) (State) (Zip Code)

 (Owner's Name - Please Print)

 (Owner's Mailing Address)

 (Owner's Signature)

 (City) (State) (Zip Code)

 (Owner's Name - Please Print)

 (Owner's Mailing Address)

 (Owner's Signature)

 (City) (State) (Zip Code)

(Continued on page 2)

NW/PB

PRESS FIRMLY TO SEAL

PLACE STICKER AT TOP OF ENVELOPE TO THE RIGHT OF THE RETURN ADDRESS, FOLD AT DOTTED LINE

CERTIFIED MAIL



7018 0360 0000 3120 9998

FROM

PRIORITY MAIL



1006



85004

U.S. POSTAGE PAID
TUCSON, AZ 85745
AUG 08, 18
AMOUNT

\$12.90

R2303S100357-11



VISIT US AT USPS.COM
ORDER FREE SUPPLIES ONLINE

★ MAIL ★



DATE OF DELIVERY SPECIFIED *



USPS TRACKING™ INCLUDED *



INSURANCE INCLUDED *



PICKUP AVAILABLE

* Domestic only

FROM:

1025 S. KROEGER LN,
TUCSON, AZ 85745

RETURN RECEIPT REQUESTED

TO: BLM ARIZONA

1 N. CENTRAL AVE,
STE. 800
PHOENIX, AZ 85004

Label 228, March 2016

FOR DOMESTIC AND INTERNATIONAL USE

RECEIVED
BLM AZ STATE OFFICE
2018 AUG -9 P 3:25
PHOENIX, ARIZONA



2013
9.5

VISIT US AT USPS.COM
ORDER FREE SUPPLIES ONLINE



This packaging is the property of the U.S. Postal Service® and is provided solely for use in sending Priority Mail® shipments. Misuse may be a violation of federal law. This packaging is not for resale. EPIAF © U.S. Postal Service; July 2013; All rights reserved.

This envelope is made from post-consumer waste. Please recycle.

Requested By: Keith Bowen
SUZANNE SAIN RECORDER
SANTA CRUZ COUNTY, ARIZONA
12-22-2017 01:03 PM Recording Fee \$15.00

403018

402998

When Recorded Return Document to:
Keith Bowen
1025 S. Kroeger Ln
Tucson, AZ 85745



Check here if this is a change of address.
Telephone: 520-631-6523
E-mail address: _____

AFFIDAVIT OF PERFORMANCE OF ANNUAL WORK

1. State of Arizona, County of Santa Cruz ss:
2. I (Name) Keith H. Bowen
3. Reside at (Address) 1025 S Kroeger Ln

City Tucson County Pima

BLM
Date
Stamp

RECEIVED
STATE OFFICE
2017 DEC 28 A 10:13
PHOENIX, ARIZONA

State AZ Zip 85745 being duly sworn, depose and say that I am a citizen of the United States, more than eighteen years of age, and that all of the facts set forth in this affidavit, subject to the provisions and penalties of 18 U.S.C. 1001 pertaining to the filing of false, fictitious, or fraudulent statements with the United States, are true and correct according to the best of my knowledge, information and belief.

4. Owner's name and address (If not shown in Items 1-3 above): SAME

5. That I am personally acquainted with the mining claim(s). The work and improvements were made by and at the expense of the owner(s) of said claim(s). Said contiguous group of claims, listed on this document, are situated in the

Oro Blanco (optional) Mining District; Santa Cruz County, Arizona.

Line No.	AMC NUMBER	CLAIM/SITE NAME	COUNTY RECORDER DATA (If available)	TWP.	RNG	SEC
1	403034		2010-08112	22S	10E	26
2	403035		2010-08113	22S	10E	26/35
3	403036		2010-08114	22S	10E	26
4						
5						
6						

ENTERED
DEC 29 2017
RAM

RECEIVED
 STATE OFFICE
 2011 DEC 28 A 10:13
 PHOENIX, ARIZONA
 BLM
 Date
 Stamp

7						
8						
9						
10						

6. That between the dates starting at 12 o'clock noon on September 1, 20 16 and ending at 12 o'clock noon on September 1, 20 17 at least \$ 500 dollars worth of work and improvements were done and performed upon said claim(s) or upon one or more of a contiguous group of claims for the benefit of all, wholly or partly outside of a contiguous group of claims for the benefit of all, not including the location work.

7. That the following persons were employed to perform the work and improvements described herein: SELF

8. That the work and improvements performed were: ROAD MAINTENANCE, EQUIPMENT MAINTENANCE, SAMPLING, METALLURGICAL TESTING, MAINTAIN MONUMENTS

9. Dated: 12/22/17 Signature: [Signature]

SUBSCRIBED AND SWORN TO before me, a Notary Public, this 22 day of December 20 17

By: Keith Henry Bowen

Notary Public [Signature]

My Commission Expires 10/12/2021

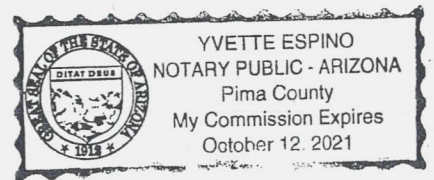

Bureau of Land Management
 Arizona State Office
www.blm.gov/az

No. of Claims: _____ x \$10 = _____
 Check No.: _____ Init. [Signature]
 Receipt No.: 4051917
 For BLM Use Only



W
KEITH BOWEN
1025 S KROEGER LN
TUCSON AZ 85745

Telephone: 520 611 1111
E-mail address: Hard Rock @ outlook.com

AFFIDAVIT OF PERFORMANCE OF ANNUAL WORK

1. State of Arizona, County of PIMA ss:
2. I (Name) Keith H. Bowen
3. Reside at (Address) 1025 S. Kroeger Ln
City Tucson County Pima

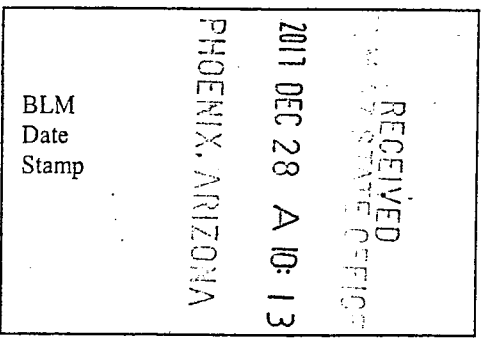

State AZ Zip 85745 being duly sworn, depose and say that I am a citizen of the United States, more than eighteen years of age, and that all of the facts set forth in this affidavit, subject to the provisions and penalties of 18 U.S.C. 1001 pertaining to the filing of false, fictitious, or fraudulent statements with the United States, are true and correct according to the best of my knowledge, information and belief.

4. Owner's name and address (If not shown in Items 1-3 above), Eva J. Landry,
1025 S. Kroeger Ln, Tucson, AZ 85745

5. That I am personally acquainted with the mining claim(s). The work and improvements were made by and at the expense of the owner(s) of said claim(s). Said contiguous group of claims, listed on this document, are situated in the

Las Guijas (optional) Mining District; Pima County, Arizona.

Line No.	AMC NUMBER	CLAIM/SITE NAME	COUNTY RECORDER DATA (If available)	TWP	RNG	SEC
1	403019	Back Bone North	D13916, P 919	21S	10E	8
2	403020	Back Bone South	D13916, P 899	21S	10E	8
3	403025	NY1-11	D13916, P 933	21S	10E	5
4	403026	NY1-12	D13916, P 935	21S	10E	5
5	403028	NY1-16	D13916, P 915	21S	10E	8
6	403029	NY1-17	D13916, P 917	21S	10E	8

RECEIVED
2017 DEC 28 AM 10:13
PHOENIX, ARIZONA

BLM
Date
Stamp

7	403030	NY1-18	D 13916, P 941	215	10E	8
8	403032	NY1-22	D 13916, P 949	215	10E	5
9	403033	NY1-23	D 13916, P 923	215	10E	8
10	/	/	/	/	/	/

6. That between the dates starting at 12 o'clock noon on September 1, 20 ____ and ending at 12 o'clock noon on September 1, 20 ____ at least \$ _____ dollars worth of work and improvements were done and performed upon said claim(s) or upon one or more of a contiguous group of claims for the benefit of all, wholly or partly outside of a contiguous group of claims for the benefit of all, not including the location work.

7. That the following persons were employed to perform the work and improvements described herein: _____

Thomas Parrish + 1

8. That the work and improvements performed were: cutting brush, fencing & signing mine openings, road repair, metallurgical analysis, equipment purchasing

9. Dated: 11-17-20 Signature: [Signature]

SUBSCRIBED AND SWORN TO before me, a Notary Public, this 20th day of November 2017

By: Keith H. Bowen

Notary Public Sonja A. Kukulinski

My Commission Expires Jan. 13, 2021

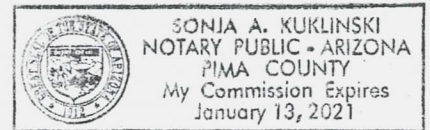

Bureau of Land Management
Arizona State Office
www.blm.gov/az

No. of Claims: _____ x \$10 = _____
 Check No.: _____ Init. _____
 Receipt No.: _____
 For BLM Use Only



W

KEITH BOWEN
1025 S KROEGER LN
TUCSON AZ 85745

Telephone: 520-631-0242

E-mail address: HardRock4@outlook.com

AFFIDAVIT OF PERFORMANCE OF ANNUAL WORK

1. State of Arizona, County of Pima ss:

2. I (Name) Keith A. Bowen

3. Reside at (Address) 1025 S. Kroeger Ln

City Tucson County PIMA

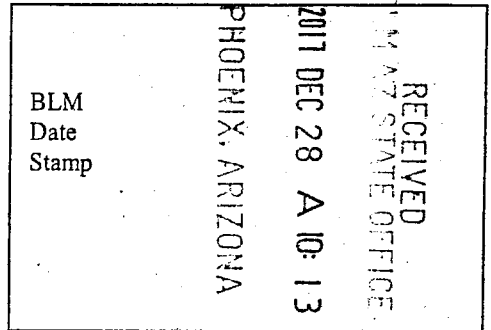

State AZ Zip 85745 being duly sworn, depose and say that I am a citizen of the United States, more than eighteen years of age, and that all of the facts set forth in this affidavit, subject to the provisions and penalties of 18 U.S.C. 1001 pertaining to the filing of false, fictitious, or fraudulent statements with the United States, are true and correct according to the best of my knowledge, information and belief.

4. Owner's name and address (If not shown in Items 1-3 above), Charles R Bowen
2739 W Julie Ln, Yuma, AZ 85365

5. That I am personally acquainted with the mining claim(s). The work and improvements were made by and at the expense of the owner(s) of said claim(s). Said contiguous group of claims, listed on this document, are situated in the

Las Guijas (optional) Mining District; Pima County, Arizona.

Line No.	AMC NUMBER	CLAIM/SITE NAME	COUNTY RECORDER DATA (If available)	TWP	RNG	SEC
1	402998	Good Enough E	D13916, P 893	20S	10E	31
2	402999	Good Enough W	D13916, P 895	20S	10E	31
3	403000	NY1-10	D13916, P 931	21S	10E	5
4	403001	NY1-20	D13916, P 947	21S	10E	5
5	403002	NY1-25	D13916, P 951	21S	10E	5
6	403003	NY1-26	D13916, P 953	21S	10E	5

RECEIVED
 2017 DEC 28 AM 10:17
 PHOENIX ARIZONA
 BLM
 Date
 Stamp

7	403004	NY1-27	D13916, P 955	215	10E	6
8	403005	NY1-28	D13916, P 957	215	10E	6
9	403006	NY1-29	D13916, P 959	215	10E	6
10	403007	NY1-35	D13916, P 961	215	10E	5

6. That between the dates starting at 12 o'clock noon on September 1, 20 ____ and ending at 12 o'clock noon on September 1, 20 ____ at least \$ _____ dollars worth of work and improvements were done and performed upon said claim(s) or upon one or more of a contiguous group of claims for the benefit of all, wholly or partly outside of a contiguous group of claims for the benefit of all, not including the location work.

7. That the following persons were employed to perform the work and improvements described herein: _____

Thomas Parrish + 1,

8. That the work and improvements performed were: brush cutting, fencing mine openings, signing, road repair, metallurgical testing, equipment purchase

9. Dated: 11-20-17 Signature: [Signature]

SUBSCRIBED AND SWORN TO before me, a Notary Public, this 20th day of Nov 2017

By: [Signature] Keith H. Bowen

Notary Public [Signature] Sonja A. Kuklinski

My Commission Expires Jan 13, 2021

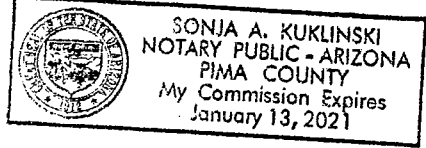

Bureau of Land Management
 Arizona State Office
www.blm.gov/az

No. of Claims: _____ x \$10 = _____
 Check No.: _____ Init. _____
 Receipt No.: _____
 For BLM Use Only

Form: MCF108
 Revised July 2014
 Page 2 of 2



W

KEITH BOWEN
1025 S KROEGER LN
TUCSON AZ 85745

Telephone: 224-621-624

E-mail address: HandRockU@outlook.com

AFFIDAVIT OF PERFORMANCE OF ANNUAL WORK

1. State of Arizona, County of Pima ss:

2. I (Name) Keith H. Bowen

3. Reside at (Address) 1025 S. Kroeger Ln

City Tucson County Pima

RECEIVED
MARIANA STATE OFFICE
2017 DEC 28 A 10:13
PHOENIX, ARIZONA
BLM
Date
Stamp

State AZ Zip 85745 being duly sworn, depose and say that I am a citizen of the United States, more than eighteen years of age, and that all of the facts set forth in this affidavit, subject to the provisions and penalties of 18 U.S.C. 1001 pertaining to the filing of false, fictitious, or fraudulent statements with the United States, are true and correct according to the best of my knowledge, information and belief.

4. Owner's name and address (If not shown in Items 1-3 above). SAME

5. That I am personally acquainted with the mining claim(s). The work and improvements were made by and at the expense of the owner(s) of said claim(s). Said contiguous group of claims, listed on this document, are situated in the

Las Guijas (optional) Mining District; Pima County, Arizona.

Line No.	AMC NUMBER	CLAIM/SITE NAME	COUNTY RECORDER DATA (If available)	TWP	RNG	SEC
1	403021	NY1-1	D13916, P 901	21S	10E	4
2	403022	NY1-2	D13916, P 903	21S	10E	4
3	403023	NY1-6	D13916, P 907	21S	10E	5
4	403024	NY1-7	D13916, P 909	21S	10E	5
5	403027	NY1-13	D13916, P 913	21S	10E	5
6	403031	NY1-21	D13916, P 921	21S	10E	5

RECEIVED
PIMA AZ

2017 OCT 20 AM 10:10
PHOENIX

BLM
Date
Stamp

7	403018	Angelita	D18916, P 897	215	10E	8
8						
9						
10						

6. That between the dates starting at 12 o'clock noon on September 1, 20____ and ending at 12 o'clock noon on September 1, 20____ at least \$_____dollars worth of work and improvements were done and performed upon said claim(s) or upon one or more of a contiguous group of claims for the benefit of all, wholly or partly outside of a contiguous group of claims for the benefit of all, not including the location work.

7. That the following persons were employed to perform the work and improvements described herein: _____

Thomas Pannish & 1 other

8. That the work and improvements performed were: brush clearing & fencing & signing dangerous openings, road repair, metallurgical work, equipment purchase

9. Dated: 11-20-17 Signature: _____

SUBSCRIBED AND SWORN TO before me, a Notary Public, this 20th day of November 2017

By: Keith H. Bowen

Notary Public Sonja A. Kuklinski

My Commission Expires Jan. 13, 2021

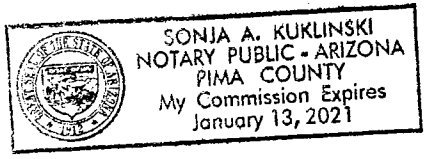

Bureau of Land Management
Arizona State Office
www.blm.gov/az

No. of Claims: _____ x \$10 = _____

Check No.: _____ Init. _____

Receipt No.: _____

For BLM Use Only

**United States Department of the Interior
Bureau of Land Management
DIV OF LANDS, MINRLS & ENERGY
ONE N CENTRAL AVE
PHOENIX, AZ 85004 -4427
Phone: 602-417-9200**

Receipt

No: 4051917

Transaction #: 4163411	
Date of Transaction: 12/28/2017	
CUSTOMER:	
KEITH H BOWEN 1025 S KROEGER LN TUCSON, AZ 85745-3070 US	

LINE #	QTY	DESCRIPTION	REMARKS	UNIT PRICE	TOTAL
1	1.00	LOCATABLE MINERALS / MINING CLAIMS- NOT NEW-UNADJUD, ONE AUTH NO. ONLY / MINING CLAIM MONEY RECEIVED CASES: AMC403034/\$290.00		- n/a -	290.00
TOTAL:					\$290.00

PAYMENT INFORMATION				
NOTE: Items will appear on credit card statement as "Bureau of Land Mgmt CO".				
1	AMOUNT:	290.00	POSTMARKED:	N/A
	TYPE:	CREDIT CARD	RECEIVED:	12/28/2017
	NAME:	BOWEN, KEITH H 1025 S KROEGER LN TUCSON AZ 85745-3070 US		
	CARD NO:	XXXXXXXXXXXX3145	AUTH CODE:	122907
	NAME ON CARD:	KEITH BOWEN		
	EXPIRES:	03/2021		
	SIGNATURE:			

REMARKS

This receipt was generated by the automated BLM Collections and Billing System and is a paper representation of a portion of the official electronic record contained therein.

UNITED STATES
DEPARTMENT OF THE INTERIOR
BUREAU OF LAND MANAGEMENT

193

PER

Amc 402998

MAINTENANCE FEE WAIVER CERTIFICATION

FORM APPROVED
OMB NO. 1004-0114
Expires: October 31, 2016

SEE INSTRUCTIONS ON PAGE 2

1. This small miner waiver is filed for the assessment year beginning on September 1, 2017 and ending on September 1, 2018
2. The undersigned and all related parties owned ten or fewer mining claims, mill, or tunnel sites located and maintained on Federal lands in the United States of America on September 1, 2017
3. The undersigned have performed the assessment work required by law for each mining claim listed prior to filing this waiver and understand that by filing this form, the undersigned must file an affidavit of assessment work with the Bureau of Land Management (BLM) by the December 30th following the filing of this waiver.
4. The undersigned understand that if the assessment work obligation has not yet come due under 30 U.S.C. 28 (for those claims in their first assessment year only), a notice of intent to hold reciting this condition must be recorded by the December 30th following the filing of this waiver.
5. The undersigned understand that mill and tunnel sites may also be listed on this waiver and be waived from payment of the maintenance fee, and that a notice of intent to hold for these sites is required to be filed with the BLM by the December 30th following the filing of this waiver.
6. The undersigned understand and acknowledge that pursuant to 43 U.S.C. 1212 and 18 U.S.C. 1001, the filing or recording of a false, fictitious, or fraudulent document with the BLM may result in a fine of up to \$250,000, a prison term not to exceed five years, or both.
7. The mining claims, mill or tunnel sites for which this waiver from payment of the maintenance fees is requested are:

CLAIM OR SITE NAME	BLM RECORDATION SERIAL NUMBER
1. Good Enough E	✓ AMC 402998
2. Good Enough W	AMC 402999
3. NYI-10	AMC 403000
4. NYI-20	AMC 403001
5. NYI-25	AMC 403002
6. NYI-26	AMC 403003
7. NYI-27	AMC 403004
8. NYI-28	AMC 403005
9. NYI-29	AMC 403006
10. NYI-35	AMC 403007

The owner(s) (claimants) of the above mining claims and sites are:

Charles R Bowen
(Owner's Name - Please Print)

2739 W Julie Ln
(Owner's Mailing Address)

[Handwritten Signature]

(Owner's Signature)

Yuma AZ 85365
(City) (State) (Zip Code)

(Owner's Name - Please Print)

(Owner's Mailing Address)

(Owner's Signature)

(City) (State) (Zip Code)

(Owner's Name - Please Print)

(Owner's Mailing Address)

(Owner's Signature)

(City) (State) (Zip Code)

(Owner's Name - Please Print)

(Owner's Mailing Address)

(Owner's Signature)

(City) (State) (Zip Code)

483
ENTERED
SEP 06 2017
BY: *[Signature]*

RECEIVED
BLM AT STATE OFFICE
PHOENIX, ARIZONA
2017 AUG 18 A 9:38

[Handwritten initials]

UNITED STATES
DEPARTMENT OF THE INTERIOR
BUREAU OF LAND MANAGEMENT

MAINTENANCE FEE WAIVER CERTIFICATION

209

FORM APPROVED
OMB NO. 1004-0114
Expires: October 31, 2016

402998

SEE INSTRUCTIONS ON PAGE 2

- This small miner waiver is filed for the assessment year beginning on September 1, 2016 and ending on September 1, 2017
- The undersigned and all related parties owned ten or fewer mining claims, mill, or tunnel sites located and maintained on Federal lands in the United States of America on September 1, 2016
- The undersigned have performed the assessment work required by law for each mining claim listed prior to filing this waiver and understand that by filing this form, the undersigned must file an affidavit of assessment work with the Bureau of Land Management (BLM) by the December 30th following the filing of this waiver.
- The undersigned understand that if the assessment work obligation has not yet come due under 30 U.S.C. 28 (for those claims in their first assessment year only), a notice of intent to hold reciting this condition must be recorded by the December 30th following the filing of this waiver.
- The undersigned understand that mill and tunnel sites may also be listed on this waiver and be waived from payment of the maintenance fee, and that a notice of intent to hold for these sites is required to be filed with the BLM by the December 30th following the filing of this waiver.
- The undersigned understand and acknowledge that pursuant to 43 U.S.C. 1212 and 18 U.S.C. 1001, the filing or recording of a false, fictitious, or fraudulent document with the BLM may result in a fine of up to \$250,000, a prison term not to exceed five years, or both.
- The mining claims, mill or tunnel sites for which this waiver from payment of the maintenance fees is requested are:

CLAIM OR SITE NAME	BLM RECORDATION SERIAL NUMBER
1. Good Enough E	AMC 402998 ✓
2. Good Enough W	AMC 402999
3. NYI-10	AMC 403000
4. NYI-20	AMC 403001
5. NYI-25	AMC 403002
6. NYI-26	AMC 403003
7. NYI-27	AMC 403004
8. NYI-28	AMC 403005
9. NYI-29	AMC 403006
10. NYI-35	AMC 403007

The owner(s) (claimants) of the above mining claims and sites are:

Charles R Bowen
(Owner's Name - Please Print)
2739 W Julie Ln
(Owner's Mailing Address)

[Signature]
(Owner's Signature)
Yuma AZ 85365
(City) (State) (Zip Code)

(Owner's Name - Please Print)

(Owner's Mailing Address)

(Owner's Signature)

(City) (State) (Zip Code)

(Owner's Name - Please Print)

(Owner's Mailing Address)

(Owner's Signature)

(City) (State) (Zip Code)

(Owner's Name - Please Print)

(Owner's Mailing Address)

(Owner's Signature)

(City) (State) (Zip Code)

ENTERED
483
SEP 01 2016

PHOENIX, ARIZONA
2016 AUG 11 11:01
RECEIVED
BLM AZ STATE OFFICE

BY: [Signature]

[Signature]

(Owner's Name - Please Print)

(Owner's Signature)

(Owner's Mailing Address)

(City)

(State)

(Zip Code)

(Owner's Name - Please Print)

(Owner's Signature)

(Owner's Mailing Address)

(City)

(State)

(Zip Code)

(Owner's Name - Please Print)

(Owner's Signature)

(Owner's Mailing Address)

(City)

(State)

(Zip Code)

(Owner's Name - Please Print)

(Owner's Signature)

(Owner's Mailing Address)

(City)

(State)

(Zip Code)

RECEIVED
BLM AZ STATE OFFICE
2015 AUG 11 11:01
PHOENIX, ARIZONA

18 U.S.C. 1001 and 43 U.S.C. 1212 make it a crime for any person knowingly and willfully to make to any department or agency of the United States any false, fictitious or fraudulent statements or representations as to any matter within its jurisdiction.

INSTRUCTIONS

1. This certification is made under the provisions of 43 U.S.C. § 1744 and 30 U.S.C. §28-28k and the regulations thereunder (43 CFR Part 3830).
2. The claimant(s) must fill in the dates in paragraph 1 for the beginning and ending of the assessment year for which this waiver is sought.
3. The claimant(s) must fill in the date in paragraph 2 for the beginning of the assessment year for which this waiver is sought.
4. All claim and site names and BLM serial numbers must be listed for the mining claims, mill sites, and tunnel sites for which the waiver is sought.
5. All owners of the mining claims, mill sites, and tunnel sites and their addresses must be given.
6. This waiver form must be signed by all the claimants or their designated agent, in original form. If an agent is designated, a notarized designation of agent, signed by all of the claimants with proper address given, must be submitted with this waiver.
7. This form must be filed no later than September 1st for the upcoming assessment year in the BLM State Office where the mining claims or sites are recorded, or the waiver cannot be granted by the BLM. (Example: To obtain a waiver for the assessment year 2012, which begins on September 1, 2011, you must qualify for and file for a waiver no later than September 1, 2011, in the proper BLM State Office.)
8. For all mining claims which require assessment work, you must record an affidavit of labor on or before the December 30th immediately following the filing of this waiver. For all other mining claims or sites waived, you must record a notice of intent to hold on or before the December 30th immediately following the filing of this waiver.
9. Mill and tunnel sites may also be listed on this waiver and be waived from payment of the maintenance fee. A notice of intent to hold for these sites is required to be filed by the December 30th following the filing of this waiver.

FOR OFFICIAL USE ONLY

UNITED STATES
DEPARTMENT OF THE INTERIOR
BUREAU OF LAND MANAGEMENT

FORM APPROVED
OMB NO.: 1004-0114
Expires: October 31, 2016

AFFIDAVIT OF ANNUAL ASSESSMENT WORK

403018

402998

WHEN RECORDED, MAIL DOCUMENT TO:

NAME: Keith Bowen

ADDRESS: 1025 S Kroeger Ln

CITY, STATE, ZIP: Tucson, AZ 85745

2016-07108
Page 1 of 4
Requested By: Keith Bowen
SUZANNE SAINZ, RECORDER
SANTA CRUZ COUNTY, ARIZONA
10-28-2016 12:46 PM Recording Fee \$15.00

FOR COUNTY RECORDER'S USE

No. of Claims 3

x \$10/claim

Total due BLM \$ 30.00

TO ALL WHOM IT MAY CONCERN:

1. The undersigned certifies that at least \$100 per claim was expended for development, labor and improvements, or equivalent value added, as the annual assessment work for the assessment year ending September 1, 2016 for the following contiguous unpatented mining claim(s), located in the County of Santa Cruz, in the State of ARIZONA.

BLM Serial No.	Name of Claim	Tp	Rg	Sec	Mer	County Recordation Book and Page No.	Date
403034	St Christopher #1	22S	10E	26	GSR	2010-08112	10-18-10
403035	St Christopher #2	22S	10E	26/35	GSR	2010-08113	10-18-10
403036	St Christopher #3	22S	10E	26	GSR	2010-08114	10-18-10

RECEIVED
BLM AZ STATE OFFICE
2016 DEC 20 A 11:25
PHOENIX, ARIZONA

3725795

(Continued on page 2)

DEC 21 2016
Rpm

2. Type of labor and improvements (specify what was done and give the total value for that labor and improvement to show at least \$100 for each claim). If a geological, geochemical, or geophysical survey was performed, as per 30 U.S.C. 28-1, reference the title of the report of survey, give cost and date of the survey and report, and indicate it was filed with the County Recorder:

Description of Work Performed	Value of Work Performed	Date Work Was Performed
Metallurgical Extraction Testing	\$1000 Jan 2016	Jan 2016
Maintenance of Monuments	\$150 Feb 8 2016	Feb 8 2016

3. Name and mailing address of each person who performed the labor and improvements:

<p>Name (please print) <u>Keith Bown</u></p> <p>_____</p> <p>_____</p> <p>_____</p>	<p>Current Mailing Address (please print) <u>1025 S Kroeger Ln, Tucson, 8574</u></p> <p>_____</p> <p>_____</p> <p>_____</p>
---	---

4. Name and mailing address of each person who holds and claims the subject mining claim(s) for the valuable minerals contained therein. Be sure to indicate if there is a change of address:

<p>Name (please print) <u>Keith Bown</u></p> <p>_____</p> <p>_____</p> <p>_____</p> <p>_____</p> <p>_____</p>	<p>Current Mailing Address (please print) <u>1025 S Kroeger Ln, Tucson, 857</u></p> <p>_____</p> <p>_____</p> <p>_____</p> <p>_____</p> <p>_____</p>
---	--

5. The undersigned testifies that on the date of Feb 8, 2016, all monuments required by law were erected upon the subject claim(s), and all notices required by law were posted on the subject claim(s) or copies thereof were in place, and at said date, each corner monument bore or contained

markings sufficient to appropriately designate the corner of the claim to which it pertains and the name of the claim(s).

I hereby certify under penalty of perjury under the laws of the State of Arizona that the foregoing statements are true and correct:

[Signature]
(Signature of person responsible for above statement)

Date: 10-28-16

Title 18 U.S.C. 1001 and 43 U.S.C. 1212 make it a crime for any person knowingly and willfully to make to any department or agency of the United States any false, fictitious or fraudulent statements or representations as to any matter within its jurisdiction.

Notary Block

SUBSCRIBED AND SWORN TO before me, this 25th day of October 2016

By: Keith H. Bowen [Signature]
(Signature of Affiant) notary

Title: Relationship Banker

My Commission Expires: 12/25/16



INSTRUCTIONS

1. This is an optional form that may be used to satisfy the requirements for the Bureau of Land Management (BLM) under the provisions of 43 U.S.C. §1744 and 30 U.S.C. §28-28d and the regulations thereunder (43 CFR part 3835). Since local and State laws may vary, you should contact your local and State agencies where the claims are located to ensure all applicable laws and requirements are satisfied.
2. The claimant(s) must fill in the date in paragraph 1 for the applicable assessment year and the county and state where the claims are located.
3. All claim names, BLM serial numbers, legal descriptions, and original county recording information must be listed for the claims pertaining to this assessment notice.
4. The claimant(s) must complete paragraph 2 listing all labor or improvements which was performed on or did benefit the subject mining claims. The value and date of the labor or improvements must also be listed. The total amount of labor or improvements can be listed, but the total expenditure must equal at least \$100 for each claim.
5. The names and current mailing addresses of the person(s) performing the labor shall be listed in paragraph 3.
6. The name and current mailing address of each owner (claimant) of the claims shall be listed in paragraph 4. The mailing address shall be the owner's address and not the address of an agent or anyone representing the claimant. Be sure to note if there has been a change of address.
7. Paragraph 5 shall be completed to show the date it was verified that all monuments required by law were properly erected, all notices were posted, and that corners were appropriately designated for all claims listed.
8. An exact legible reproduction or duplicate (other than microfilm or other electronic media) of this affidavit or another type of affidavit of assessment work that you file or will file in the county where each claim is located, must be filed with the BLM on or before December 30 of the calendar year in which the assessment year ends. For mill or tunnel sites, a separate notice of intent to hold must be filed with the BLM on or before December 30. Requirements for filing a notice of intent to hold can be found at 43 CFR 3835.33.
9. A processing fee of \$10 for each claim listed must be remitted to the BLM along with this or any other affidavit of assessment work.

RECEIVED
STATE OFFICE
NOV 20 11:25
TUCSON, ARIZONA

(Continued on page 4)

(Form 3830-4, page 3)

NOTICES

THE PRIVACY ACT and 43 CFR 2.48(d) require that you be furnished with the following information in connection with the information requested by this form.

AUTHORITY: 30 U.S.C. §28-28d and 43 CFR part 3835 permit collection of the information requested by this form.

PRINCIPAL PURPOSE: The BLM will use the information you provide to document compliance with 43 U.S.C. 1744 and that assessment work has been completed in accordance with 30 U.S.C. § 28-28d and 43 CFR part 3835 in lieu of paying the maintenance fee for the mining claims listed on this form.

ROUTINE USES: The BLM will only disclose this information in accordance with the provisions at 43 CFR 2.56(b) and (c).

EFFECT OF NOT PROVIDING INFORMATION: Disclosure of the requested information is required by 30 U.S.C. § 28-28d and 43 CFR part 3835 for claimants qualified to perform assessment work in lieu of paying the maintenance fee. Failure to submit all the requested information or to complete this form will delay the BLM's processing of the form and may preclude the BLM's acceptance of the assessment work information, which may result in forfeiture of the mining claim(s) by the claimant.

THE PAPERWORK REDUCTION ACT requires us to inform you that:

Use of this form is optional. You must perform assessment if a waiver to pay the maintenance fee has been requested. This form is provided to help you attest that annual assessment work has been completed in lieu of paying the maintenance fee for your claim(s). Submission of the requested information is necessary to obtain or retain a benefit.

You do not have to respond to this or any other Federal agency-sponsored information collection unless it displays a valid OMB control number.

BURDEN HOURS STATEMENT: The estimated public reporting burden for this form is 30 minutes per response, including the time for reviewing instructions, gathering and maintaining data, and completing and reviewing the form. You may submit comments regarding the burden estimate or any other aspect of this form to: U.S. Department of the Interior, Bureau of Land Management (1004-0114), Bureau Information Collection Clearance Officer (WO-630), 1849 C Street, N.W., Room 2134LM, Washington, D.C. 20240.

UNITED STATES
DEPARTMENT OF THE INTERIOR
BUREAU OF LAND MANAGEMENT

FORM APPROVED
OMB NO.: 1004-0114
Expires: October 31, 2016

AFFIDAVIT OF ANNUAL ASSESSMENT WORK

RECEIVED
BLM AZ STATE OFFICE
2016 DEC 20 A 11: 25
PHOENIX, ARIZONA

WHEN RECORDED, MAIL DOCUMENT TO:

NAME: Kerly Bowen

ADDRESS: 1025 Kroeger Ln

CITY, STATE, ZIP: Tucson, AZ 85745

FOR COUNTY RECORDER'S USE

No. of Claims 7

x \$10/claim

Total due BLM \$ 70.00

TO ALL WHOM IT MAY CONCERN:

1. The undersigned certifies that at least \$100 per claim was expended for development, labor and improvements, or equivalent value added, as the annual assessment work for the assessment year ending September 1, 2016 for the following contiguous unpatented mining claim(s), located in the County of Pima, in the State of ARIZONA.

BLM Serial No.	Name of Claim	Twp	Rg	Sec	Mer	County Description Block and Page No.	Date
403021	NY1-1	21S	10E	4	6SR	D13916, P 901	
403022	NY1-2	21S	10E	4	6SR	D13916, P 903	
403023	NY1-6	21S	10E	5	6SR	D13916, P 907	
403024	NY1-7	21S	10E	5	6SR	D13916, P 909	
403027	NY1-13	21S	10E	5	6SR	D13916, P 913	
403031	NY1-21	21S	10E	5	6SR	D13916, P 921	
403018	Angelita	21S	10E	8	6SR	D18916, P 897	

2. Type of labor and improvements (specify what was done and give the total value for that labor and improvement to show at least \$100 for each claim). If a geological, geochemical, or geophysical survey was performed, as per 30 U.S.C. 28-1, reference the title of the report of survey, give cost and date of the survey and report, and indicate it was filed with the County Recorder:

Description of Work Performed	Value of Work Performed	Date Work Was Performed
Metallurgical extraction testing	\$800	Feb 2016
Maintenance of monuments	\$200	Feb 2016
Road Repair	\$200	Feb 2016

3. Name and mailing address of each person who performed the labor and improvements:

Name (please print)

Kath Bowa

Current Mailing Address (please print)

1025 S Kroeger Ln Tucson AZ

85745

4. Name and mailing address of each person who holds and claims the subject mining claim(s) for the valuable minerals contained therein. Be sure to indicate if there is a change of address:

Name (please print)

Kath Bowa

Current Mailing Address (please print)

1025 S Kroeger Ln Tucson 85745

5. The undersigned testifies that on the date of March 1, 2016 all monuments required by law were erected upon the subject claim(s), and all notices required by law were posted on the subject claim(s) or copies thereof were in place, and at said date, each corner monument bore or contained

markings sufficient to appropriately designate the corner of the claim to which it pertains and the name of the claim(s).

I hereby certify under penalty of perjury under the laws of the State of ARIZONA that the foregoing statements are true and correct:

[Signature]
(Signature of person responsible for above statement)

Date: 10-28-16

Title 18 U.S.C. 1001 and 43 U.S.C. 1212 make it a crime for any person knowingly and willfully to make to any department or agency of the United States any false, fictitious or fraudulent statements or representations as to any matter within its jurisdiction.

Notary Block

SUBSCRIBED AND SWORN TO before me, this 28th day of October 2016

By: [Signature]
(Signature of Affiant) notary

Title: Relationship Banker

My Commission Expires: 12/25/16

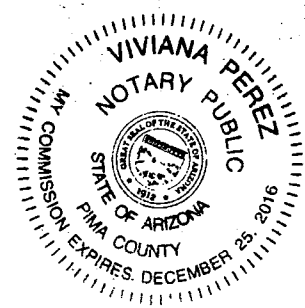

INSTRUCTIONS

1. This is an optional form that may be used to satisfy the requirements for the Bureau of Land Management (BLM) under the provisions of 43 U.S.C. §1744 and 30 U.S.C. §28-28d and the regulations thereunder (43 CFR part 3835). Since local and State laws may vary, you should contact your local and State agencies where the claims are located to ensure all applicable laws and requirements are satisfied.
2. The claimant(s) must fill in the date in paragraph 1 for the applicable assessment year and the county and state where the claims are located.
3. All claim names, BLM serial numbers, legal descriptions, and original county recording information must be listed for the claims pertaining to this assessment notice.
4. The claimant(s) must complete paragraph 2 listing all labor or improvements which was performed on or did benefit the subject mining claims. The value and date of the labor or improvements must also be listed. The total amount of labor or improvements can be listed, but the total expenditure must equal at least \$100 for each claim.
5. The names and current mailing addresses of the person(s) performing the labor shall be listed in paragraph 3.
6. The name and current mailing address of each owner (claimant) of the claims shall be listed in paragraph 4. The mailing address shall be the owner's address and not the address of an agent or anyone representing the claimant. Be sure to note if there has been a change of address.
7. Paragraph 5 shall be completed to show the date it was verified that all monuments required by law were properly erected, all notices were posted, and that corners were appropriately designated for all claims listed.
8. An exact legible reproduction or duplicate (other than microfilm or other electronic media) of this affidavit or another type of affidavit of assessment work that you file or will file in the county where each claim is located, must be filed with the BLM on or before December 30 of the calendar year in which the assessment year ends. For mill or tunnel sites, a separate notice of intent to hold must be filed with the BLM on or before December 30. Requirements for filing a notice of intent to hold can be found at 43 CFR 3835.33.
9. A processing fee of \$10 for each claim listed must be remitted to the BLM along with this or any other affidavit of assessment work.

(Continued on page 4)

RECEIVED
BLM AZ STATE OFFICE
NOV 16 DEC 20 11:25
PHOENIX, ARIZONA
(Form 3830 (Rev. 3))

AFFIDAVIT OF ANNUAL ASSESSMENT WORK

WHEN RECORDED, MAIL DOCUMENT TO:

NAME: Keith Bowen

ADDRESS: 1025 S Kroeger Ln

CITY, STATE, ZIP: Tucson, AZ 85745

RECEIVED
BLM AZ STATE OFFICE
2016 DEC 20 A 11: 25
PHOENIX, ARIZONA

FOR COUNTY RECORDER'S USE

No. of Claims 9
x \$10/claim
Total due BLM \$ 90.00

TO ALL WHOM IT MAY CONCERN:

1. The undersigned certifies that at least \$100 per claim was expended for development, labor and improvements, or equivalent value added, as the annual assessment work for the assessment year ending September 1, 2016 for the following contiguous unpatented mining claim(s), located in the County of Pima, in the State of Arizona.

BLM Serial No.	Name of Claim	T14	R2	Sec	Min	County Description Book and Page No.	Date
403019	Back Bone North	215	10E	8	6SR	D 13916, P 919	
403020	Back Bone South	215	10E	8	6SR	D 13916, P 899	
403025	NY1-11	215	10E	5	6SR	D 13916, P 933	
403026	NY1-12	215	10E	5	6SR	D 13916, P 935	
403028	NY1-16	215	10E	8	6SR	D 13916, P 915	
403029	NY1-17	215	10E	8	6SR	D 13916, P 917	
403030	NY1-18	215	10E	8	6SR	D 13916, P 941	
403032	NY1-22	215	10E	5	6SR	D 13916, P 949	
403033	NY1-23	215	10E	8	6SR	D 13916, P 923	

2. Type of labor and improvements (specify what was done and give the total value for that labor and improvement to show at least \$100 for each claim). If a geological, geochemical, or geophysical survey was performed, as per 30 U.S.C. 28-1, reference the title of the report of survey, give cost and date of the survey and report, and indicate it was filed with the County Recorder.

Description of Work Performed	Value of Work Performed	Date Work Was Performed
Metallurgical Extraction Testing	\$1000	Feb 2016
Maintenance of Monuments	\$200	Feb 2016
Road Repair	\$200	Feb 2016

3. Name and mailing address of each person who performed the labor and improvements:

Name (please print)

~~Eva J. L~~
 Keith Bowen

Current Mailing Address (please print)

1025 S Kroeger Ln Tucson 85745

4. Name and mailing address of each person who holds and claims the subject mining claim(s) for the valuable minerals contained therein. Be sure to indicate if there is a change of address:

Name (please print)

Eva J. Laundry

Current Mailing Address (please print)

1025 S Kroeger Ln Tucson 85745

5. The undersigned testifies that on the date of March 1, 2016, all monuments required by law were erected upon the subject claim(s), and all notices required by law were posted on the subject claim(s) or copies thereof were in place, and at said date, each corner monument bore or contained

markings sufficient to appropriately designate the corner of the claim to which it pertains and the name of the claim(s).

I hereby certify under penalty of perjury under the laws of the State of Arizona that the foregoing statements are true and correct:

[Signature] Date: 10-28-16
(Signature of person responsible for above statement)

Title 18 U.S.C. 1001 and 43 U.S.C. 1212 make it a crime for any person knowingly and willfully to make to any department or agency of the United States any false, fictitious or fraudulent statements or representations as to any matter within its jurisdiction.

Notary Block

SUBSCRIBED AND SWORN TO before me, this 28th day of October 2016

By: [Signature]
(Signature of Affiant)

Title: Relationship Banker

My Commission Expires: 12/25/16

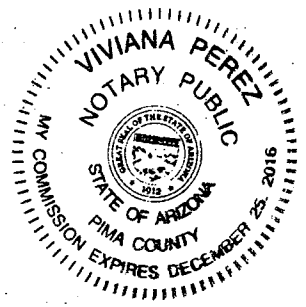

INSTRUCTIONS

1. This is an optional form that may be used to satisfy the requirements for the Bureau of Land Management (BLM) under the provisions of 43 U.S.C. §1744 and 30 U.S.C. §28-28d and the regulations thereunder (43 CFR part 3835). Since local and State laws may vary, you should contact your local and State agencies where the claims are located to ensure all applicable laws and requirements are satisfied.
2. The claimant(s) must fill in the date in paragraph 1 for the applicable assessment year and the county and state where the claims are located.
3. All claim names, BLM serial numbers, legal descriptions, and original county recording information must be listed for the claims pertaining to this assessment notice.
4. The claimant(s) must complete paragraph 2 listing all labor or improvements which was performed on or did benefit the subject mining claims. The value and date of the labor or improvements must also be listed. The total amount of labor or improvements can be listed, but the total expenditure must equal at least \$100 for each claim.
5. The names and current mailing addresses of the person(s) performing the labor shall be listed in paragraph 3.
6. The name and current mailing address of each owner (claimant) of the claims shall be listed in paragraph 4. The mailing address shall be the owner's address and not the address of an agent or anyone representing the claimant. Be sure to note if there has been a change of address.
7. Paragraph 5 shall be completed to show the date it was verified that all monuments required by law were properly erected, all notices were posted, and that corners were appropriately designated for all claims listed.
8. An exact legible reproduction or duplicate (other than microfilm or other electronic media) of this affidavit or another type of affidavit of assessment work that you file or will file in the county where each claim is located, must be filed with the BLM on or before December 30 of the calendar year in which the assessment year ends. For mill or tunnel sites, a separate notice of intent to hold must be filed with the BLM on or before December 30. Requirements for filing a notice of intent to hold can be found at 43 CFR 3835.33.
9. A processing fee of \$10 for each claim listed must be remitted to the BLM along with this or any other affidavit of assessment work.

RECEIVED
MILPITAS STATE OFFICE
OCT 20 11:25
MILPITAS, ARIZONA

UNITED STATES
DEPARTMENT OF THE INTERIOR
BUREAU OF LAND MANAGEMENT

AFFIDAVIT OF ANNUAL ASSESSMENT WORK

WHEN RECORDED, MAIL DOCUMENT TO:

NAME: Keith Bowen

ADDRESS: 1025 S Kroeger Ln

CITY, STATE, ZIP: Tulson, AZ 85745

RECEIVED
BLM AZ STATE OFFICE
2016 DEC 20 A 11:25
PHOENIX, ARIZONA

FOR COUNTY RECORDER'S USE

No. of Claims 10

x \$10/claim

Total due BLM \$ 100.00

TO ALL WHOM IT MAY CONCERN:

1. The undersigned certifies that at least \$100 per claim was expended for development, labor and improvements, or equivalent value added, as the annual assessment work for the assessment year ending September 1, 2016 for the following contiguous unpatented mining claim(s), located in the County of PIMA, in the State of ARIZONA.

BLM Serial No.	Name of Claim	Ty	Eq	Sec	Min	County Description Book and Page No.	Date
402998	Good Enough E	20S	10E	31	6SR	D13916, P 893	
402999	Good Enough W	20S	10E	31	6SR	D13916, P 895	
403000	NYI-10	21S	10E	5	6SR	D13916, P 931	
403001	NYI-20	21S	10E	5	6SR	D13916, P 947	
403002	NYI-25	21S	10E	5	6SR	D13916, P 951	
403003	NYI-26	21S	10E	5	6SR	D13916, P 953	
403004	NYI-27	21S	10E	6	6SR	D13916, P 955	
403005	NYI-28	21S	10E	6	6SR	D13916, P 957	
403006	NYI-29	21S	10E	6	6SR	D13916, P 959	
403007	NYI-35	21S	10E	5	6SR	D13916, P 961	

2. Type of labor and improvements (specify what was done and give the total value for that labor and improvement to show at least \$100 for each claim). If a geological, geochemical, or geophysical survey was performed, as per 30 U.S.C. 28-1, reference the title of the report of survey, give cost and date of the survey and report, and indicate it was filed with the County Recorder:

Description of Work Performed	Value of Work Performed	Date Work Was Performed
metallurgical EXTIMATION TESTING	\$1500	Feb 2016
MAINTENANCE OF MONUMENTS	\$200	Feb 2016
ROAD REPAIR	\$200	Feb 2016

3. Name and mailing address of each person who performed the labor and improvements:

Name (please print)

Ruth Bower

Current Mailing Address (please print)

1025 S Kroeger Ln Tucson 85745

4. Name and mailing address of each person who holds and claims the subject mining claim(s) for the valuable minerals contained therein. Be sure to indicate if there is a change of address:

Name (please print)

Charles Bower

Current Mailing Address (please print)

2739^W Julie Ln, Yuma, AZ 85365

5. The undersigned testifies that on the date of Mar 1, 2016 all monuments required by law were erected upon the subject claim(s), and all notices required by law were posted on the subject claim(s) or copies thereof were in place, and at said date, each corner monument bore or contained

markings sufficient to appropriately designate the corner of the claim to which it pertains and the name of the claim(s).

I hereby certify under penalty of perjury under the laws of the State of Arizona that the foregoing statements are true and correct:

[Signature]
(Signature of person responsible for above statement)

Date: 10-28-16

Title 18 U.S.C. 1001 and 43 U.S.C. 1212 make it a crime for any person knowingly and willfully to make to any department or agency of the United States any false, fictitious or fraudulent statements or representations as to any matter within its jurisdiction.

Notary Block

SUBSCRIBED AND SWORN TO before me, this 28th day of October 2016

By: [Signature]
(Signature of Affiant)

Title: Relationship Banker

My Commission Expires: 12/25/16

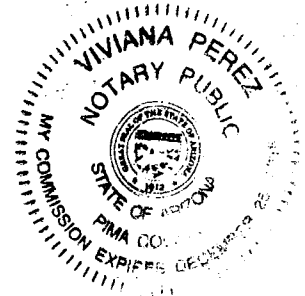

INSTRUCTIONS

1. This is an optional form that may be used to satisfy the requirements for the Bureau of Land Management (BLM) under the provisions of 43 U.S.C. §1744 and 30 U.S.C. §28-28d and the regulations thereunder (43 CFR part 3835). Since local and State laws may vary, you should contact your local and State agencies where the claims are located to ensure all applicable laws and requirements are satisfied.
2. The claimant(s) must fill in the date in paragraph 1 for the applicable assessment year and the county and state where the claims are located.
3. All claim names, BLM serial numbers, legal descriptions, and original county recording information must be listed for the claims pertaining to this assessment notice.
4. The claimant(s) must complete paragraph 2 listing all labor or improvements which was performed on or did benefit the subject mining claims. The value and date of the labor or improvements must also be listed. The total amount of labor or improvements can be listed, but the total expenditure must equal at least \$100 for each claim.
5. The names and current mailing addresses of the person(s) performing the labor shall be listed in paragraph 3.
6. The name and current mailing address of each owner (claimant) of the claims shall be listed in paragraph 4. The mailing address shall be the owner's address and not the address of an agent or anyone representing the claimant. Be sure to note if there has been a change of address.
7. Paragraph 5 shall be completed to show the date it was verified that all monuments required by law were properly erected, all notices were posted, and that corners were appropriately designated for all claims listed.
8. An exact legible reproduction or duplicate (other than microfilm or other electronic media) of this affidavit or another type of affidavit of assessment work that you file or will file in the county where each claim is located, must be filed with the BLM on or before December 30 of the calendar year in which the assessment year ends. For mill or tunnel sites, a separate notice of intent to hold must be filed with the BLM on or before December 30. Requirements for filing a notice of intent to hold can be found at 43 CFR 3835.33.
9. A processing fee of \$10 for each claim listed must be remitted to the BLM along with this or any other affidavit of assessment work.

RECEIVED
BLM STATE OFFICE
DENIX, ARIZONA
OCT 20 11 25
Form 3830-4, page 3)

United States Department of the Interior
Bureau of Land Management
 DIV OF LANDS, MINRLS & ENERGY
 ONE N CENTRAL AVE
 PHOENIX, AZ 85004 -4427
 Phone: 602-417-9200

Receipt

No: 3725795

Transaction #: 3831033	
Date of Transaction: 12/20/2016	
CUSTOMER:	
KEITH H BOWEN 1025 S KROEGER LN TUCSON, AZ 85745-3070 US	

LINE #	QTY	DESCRIPTION	REMARKS	UNIT PRICE	TOTAL
1	1.00	LOCATABLE MINERALS / MINING CLAIMS- NOT NEW-UNADJUD, ONE AUTH NO. ONLY / MINING CLAIM MONEY RECEIVED CASES: AMC403034/\$290.00	POL 2016/29	- n/a -	290.00
TOTAL:					\$290.00

PAYMENT INFORMATION			
1	AMOUNT:	290.00	POSTMARKED: N/A
	TYPE:	CASH	RECEIVED: 12/20/2016
	NAME:	BOWEN, KEITH H 1025 S KROEGER LN TUCSON AZ 85745-3070 US	

REMARKS

This receipt was generated by the automated BLM Collections and Billing System and is a paper representation of a portion of the official electronic record contained therein.



SEQUENCE: 20152920244
 NO. PAGES: 3
 AFFPL 10/19/2015
 14:48
 MAIL
 AMOUNT PAID: \$15.00

W
 KEITH BOWEN
 1025 S KROGER LN
 TUCSON AZ 85745

Form 3830-4
 (October 2013)

UNITED STATES
 DEPARTMENT OF THE INTERIOR
 BUREAU OF LAND MANAGEMENT

FORM APPROVED
 OMB NO.: 1004-0114
 Expires: October 31, 2016

AFFIDAVIT OF ANNUAL ASSESSMENT WORK

403018

402998

WHEN RECORDED, MAIL DOCUMENT TO:

NAME: Keith A. Bowen
 ADDRESS: 1025 S Kroger Ln
 CITY, STATE, ZIP: Tucson, Az 85745

FOR COUNTY RECORDER'S USE

No. of Claims 10

x \$10/claim

Total due BLM \$ 100.00

Rec
 3444807

TO ALL WHOM IT MAY CONCERN:

1. The undersigned certifies that at least \$100 per claim was expended for development, labor and improvements, or equivalent value added, as the annual assessment work for the assessment year ending September 1, 2016 for the following contiguous unpatented mining claim(s), located in the County of PIMA, in the State of ARIZONA.

BLM Serial No.	Name of Claim	Tp	Rg	Sec	Mer	County Recordation Book and Page No.	Date
402998	Good Enough E	20S	10E	31	6SR	D13916, P 893	
402999	Good Enough W	20S	10E	31	6SR	D13916, P 895	
403000	NY1-10	21S	10E	5	6SR	D13916, P 931	
403001	NY1-20	21S	10E	5	6SR	D13916, P 947	
403002	NY1-25	21S	10E	5	6SR	D13916, P 951	
403003	NY1-26	21S	10E	5	6SR	D13916, P 953	
403004	NY1-27	21S	10E	6	6SR	D13916, P 955	
403005	NY1-28	21S	10E	6	6SR	D13916, P 957	
403006	NY1-29	21S	10E	6	6SR	D13916, P 959	
403007	NY1-35	21S	10E	5	6SR	D13916, P 961	

PHOENIX, ARIZONA
 2015 DEC

BY: R.A.M.

Type of labor and improvements (specify what was done and give the total value for that labor and improvement to show at least \$100 for each claim). If a geological, geochemical, or geophysical survey was performed, as per 30 U.S.C. 28-1, reference the title of the report of survey, give cost and date of the survey and report, and indicate it was filed with the County Recorder:

Description of Work Performed	Value of Work Performed	Date Work Was Performed
Sampling	\$ 1200	Feb/march 15
road maintenance	\$ 200	Feb/march 15
corner monuments	\$ 200	Feb/march 15

Name and mailing address of each person who performed the labor and improvements:

Name (please print)

Keith A. Bowen
Keith A. Bowen

Current Mailing Address (please print)

1025 S Kroeger Ln, Tucson, AZ 85745
1025 S Kroeger Ln, Tucson, AZ 85745

Name and mailing address of each person who holds and claims the subject mining claim(s) for the valuable minerals contained therein. Be sure to indicate if there is a change of address:

Name (please print)

Keith H. Bowen

Current Mailing Address (please print)

1025 S Kroeger Ln, Tucson, AZ 85745

The undersigned testifies that on the date of April 1, 2015, all monuments required by law were erected upon the subject claim(s), and all notices required by law were posted on the subject claim(s) or copies thereof were in place, and at said date, each corner monument bore or contained

markings sufficient to appropriately designate the corner of the claim to which it pertains and the name of the claim(s).

I hereby certify under penalty of perjury under the laws of the State of ARIZONA that the foregoing statements are true and correct:

[Signature]
(Signature of person responsible for above statement)

Date: 10-19-15

Title 18 U.S.C. 1001 and 43 U.S.C. 1212 make it a crime for any person knowingly and willfully to make to any department or agency of the United States any false, fictitious or fraudulent statements or representations as to any matter within its jurisdiction.

Notary Block

SUBSCRIBED AND SWORN TO before me, this 19 day of Oct 2015

By: [Signature]
(Signature of Affiant)

Title: Notary

My Commission Expires: Nov 1, 2017

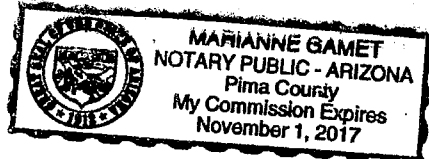

INSTRUCTIONS

1. This is an optional form that may be used to satisfy the requirements for the Bureau of Land Management (BLM) under the provisions of 43 U.S.C. §1744 and 30 U.S.C. §28-28d and the regulations thereunder (43 CFR part 3835). Since local and State laws may vary, you should contact your local and State agencies where the claims are located to ensure all applicable laws and requirements are satisfied.
2. The claimant(s) must fill in the date in paragraph 1 for the applicable assessment year and the county and state where the claims are located.
3. All claim names, BLM serial numbers, legal descriptions, and original county recording information must be listed for the claims pertaining to this assessment notice.
4. The claimant(s) must complete paragraph 2 listing all labor or improvements which was performed on or did benefit the subject mining claims. The value and date of the labor or improvements must also be listed. The total amount of labor or improvements can be listed, but the total expenditure must equal at least \$100 for each claim.
5. The names and current mailing addresses of the person(s) performing the labor shall be listed in paragraph 3.
6. The name and current mailing address of each owner (claimant) of the claims shall be listed in paragraph 4. The mailing address shall be the owner's address and not the address of an agent or anyone representing the claimant. Be sure to note if there has been a change of address.
7. Paragraph 5 shall be completed to show the date it was verified that all monuments required by law were properly erected, all notices were posted, and that corners were appropriately designated for all claims listed.
8. An exact legible reproduction or duplicate (other than microfilm or other electronic media) of this affidavit or another type of affidavit of assessment work that you file or will file in the county where each claim is located, must be filed with the BLM on or before December 30 of the calendar year in which the assessment year ends. For mill or tunnel sites, a separate notice of intent to hold must be filed with the BLM on or before December 30. Requirements for filing a notice of intent to hold can be found at 43 CFR 3835.33.
9. A processing fee of \$10 for each claim listed must be remitted to the BLM along with this or any other affidavit of assessment work.

(Continued on page 4)

(Form 3830-4, page 3)

ARIZONA
2015 DEC -2 A 10:51
RECEIVED
STATE OFFICE

F. ANN IIGUEZ, RECORDER
 Recorder : JAL
 DEPUTY RECORDER
 4916



SEQUENCE: 20152920246
 NO. PAGES: 3
 AFFPL 10/19/2015 14:48
 MAIL
 AMOUNT PAID: \$15.00

W
 KEITH BOWEN
 1025 S KROGER LN
 TUCSON AZ 85745

Form 3830-4
 (October 2013)

UNITED STATES
 DEPARTMENT OF THE INTERIOR
 BUREAU OF LAND MANAGEMENT

FORM APPROVED
 OMB NO.: 1004-0114
 Expires: October 31, 2016

AFFIDAVIT OF ANNUAL ASSESSMENT WORK

WHEN RECORDED, MAIL DOCUMENT TO:

NAME: Keith A. Bowen

ADDRESS: 1025 S. Kroger Ln

CITY, STATE, ZIP: Tucson, AZ 85745

FOR COUNTY RECORDER'S USE

No. of Claims 7
 x \$10/claim
 Total due BLM \$ 70.00

TO ALL WHOM IT MAY CONCERN:

1. The undersigned certifies that at least \$100 per claim was expended for development, labor and improvements, or equivalent value added, as the annual assessment work for the assessment year ending September 1, 2016 for the following contiguous unpatented mining claim(s), located in the County of Pima, in the State of Arizona.

BLM Serial No.	Name of Claim	Tp	Rg	Sec	Mer	County Resolution Book and Page No.	Date
403021	NY1-1	21S	10E	4	6SR	D13916, P 901	
403022	NY1-2	21S	10E	4	6SR	D13916, P 903	
403023	NY1-6	21S	10E	5	6SR	D13916, P 907	
403024	NY1-7	21S	10E	5	6SR	D13916, P 909	
403027	NY1-13	21S	10E	5	6SR	D13916, P 913	
403031	NY1-21	21S	10E	5	6SR	D13916, P 921	
403018	Angelita	21S	10E	8	6SR	D18916, P 897	

2015 DEC - 2 A 10:52
 PIMA COUNTY RECORDER

Type of labor and improvements (specify what was done and give the total value for that labor and improvement to show at least \$100 for each claim). If a geological, geochemical, or geophysical survey was performed, as per 30 U.S.C. 28-1, reference the title of the report of survey, give cost and date of the survey and report, and indicate it was filed with the County Recorder:

Description of Work Performed	Value of Work Performed	Date Work Was Performed
Sampling	\$ 1000	Feb/march 15
Road Maintenance	\$ 100	Feb/march 15
Verifying monuments	\$ 200	Feb/march 15

Name and mailing address of each person who performed the labor and improvements:

Name (please print)

Keith A. Bown
Matthew Hendry

Current Mailing Address (please print)

1025 S Kroeger Ln, Tucson, AZ 85745
1025 S Kroeger Ln, Tucson, AZ 85745

Name and mailing address of each person who holds and claims the subject mining claim(s) for the valuable minerals contained therein. Be sure to indicate if there is a change of address:

Name (please print)

Keith A. Bown

Current Mailing Address (please print)

1025 S Kroeger Ln, Tucson, AZ 85745

The undersigned testifies that on the date of April 1, 2015, all monuments required by law were erected upon the subject claim(s), and all notices required by law were posted on the subject claim(s) or copies thereof were in place, and at said date, each corner monument bore or contained

markings sufficient to appropriately designate the corner of the claim to which it pertains and the name of the claim(s).

I hereby certify under penalty of perjury under the laws of the State of Arizona that the foregoing statements are true and correct:

[Signature] Date: 10-19-11
(Signature of person responsible for above statement)

Title 18 U.S.C. 1001 and 43 U.S.C. 1212 make it a crime for any person knowingly and willfully to make to any department or agency of the United States any false, fictitious or fraudulent statements or representations as to any matter within its jurisdiction.

Notary Block

SUBSCRIBED AND SWORN TO before me, this 19 day of Oct 2011

By: [Signature]
(Signature of Affiant)

Title: Notary

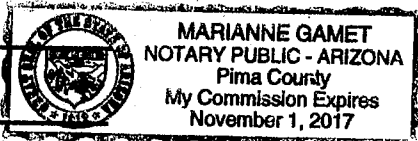

My Commission Expires: Nov 1, 2017

INSTRUCTIONS

1. This is an optional form that may be used to satisfy the requirements for the Bureau of Land Management (BLM) under the provisions of 43 U.S.C. §1744 and 30 U.S.C. §28-28d and the regulations thereunder (43 CFR part 3835). Since local and State laws may vary, you should contact your local and State agencies where the claims are located to ensure all applicable laws and requirements are satisfied.
2. The claimant(s) must fill in the date in paragraph 1 for the applicable assessment year and the county and state where the claims are located.
3. All claim names, BLM serial numbers, legal descriptions, and original county recording information must be listed for the claims pertaining to this assessment notice.
4. The claimant(s) must complete paragraph 2 listing all labor or improvements which was performed on or did benefit the subject mining claims. The value and date of the labor or improvements must also be listed. The total amount of labor or improvements can be listed, but the total expenditure must equal at least \$100 for each claim.
5. The names and current mailing addresses of the person(s) performing the labor shall be listed in paragraph 3.
6. The name and current mailing address of each owner (claimant) of the claims shall be listed in paragraph 4. The mailing address shall be the owner's address and not the address of an agent or anyone representing the claimant. Be sure to note if there has been a change of address.
7. Paragraph 5 shall be completed to show the date it was verified that all monuments required by law were properly erected, all notices were posted, and that corners were appropriately designated for all claims listed.
8. An exact legible reproduction or duplicate (other than microfilm or other electronic media) of this affidavit or another type of affidavit of assessment work that you file or will file in the county where each claim is located, must be filed with the BLM on or before December 30 of the calendar year in which the assessment year ends. For mill or tunnel sites, a separate notice of intent to hold must be filed with the BLM on or before December 30. Requirements for filing a notice of intent to hold can be found at 43 CFR/3835.33.
9. A processing fee of \$10 for each claim listed must be remitted to the BLM along with this or any other affidavit of assessment work.

RECEIVED
STATE OFFICE
ARIZONA
2015 DEC -2 A 10:52
RECEIVED
STATE OFFICE



SEQUENCE: 20152920245
 NO. PAGES: 3
 AFFPL 10/19/2015
 14:48
 MAIL
 AMOUNT PAID: \$15.00

W
 KEITH BOWEN
 1025 S KROGER LN
 TUCSON AZ 85745

Form 3830-4
 (October 2013)

UNITED STATES
 DEPARTMENT OF THE INTERIOR
 BUREAU OF LAND MANAGEMENT

FORM APPROVED
 OMB NO.: 1004-0114
 Expires: October 31, 2016

AFFIDAVIT OF ANNUAL ASSESSMENT WORK

WHEN RECORDED, MAIL DOCUMENT TO:

NAME: Keith H. Bowen
 ADDRESS: 1025 S Kroger Ln
 CITY, STATE, ZIP: Tucson, AZ 85745

FOR COUNTY RECORDER'S USE

No. of Claims 9
 x \$10/claim
 Total due BLM \$ 90.00

TO ALL WHOM IT MAY CONCERN:

1. The undersigned certifies that at least \$100 per claim was expended for development, labor and improvements, or equivalent value added, as the annual assessment work for the assessment year ending September 1, 2016 for the following contiguous unpatented mining claim(s), located in the County of Pima, in the State of Arizona.

BLM Serial No.	Name of Claim	Tp	Rg	Sec	Mer	County Recordation Book and Page No.	Date
403019	Back Bone North	21S	10E	8	6SR	D 13916, P 919	
403020	Back Bone South	21S	10E	8	6SR	D 13916, P 899	
403025	NY1-11	21S	10E	5	6SR	D 13916, P 933	
403026	NY1-12	21S	10E	5	6SR	D 13916, P 935	
403028	NY1-16	21S	10E	8	6SR	D 13916, P 915	
403029	NY1-17	21S	10E	8	6SR	D 13916, P 917	
403030	NY1-18	21S	10E	8	6SR	D 13916, P 941	
403032	NY1-22	21S	10E	5	6SR	D 13916, P 949	
403033	NY1-23	21S	10E	8	6SR	D 13916, P 923	

2015 DEC -2 A 10:53

Type of labor and improvements (specify what was done and give the total value for that labor and improvement to show at least \$100 for each claim). If a geological, geochemical, or geophysical survey was performed, as per 30 U.S.C. 28-1, reference the title of the report of survey, give cost and date of the survey and report, and indicate it was filed with the County Recorder:

Description of Work Performed	Value of Work Performed	Date Work Was Performed
sampling	\$ 900	Feb/march '15
road maintenance	\$ 200	Feb/march 15
erecting monuments	\$ 200	Feb/march 15

Name and mailing address of each person who performed the labor and improvements:

Name (please print)	Current Mailing Address (please print)
<u>Keith A. Bown</u>	<u>1025 S Kroeger Ln, Tucson, AZ 85745</u>
<u>Matthew Hendry</u>	<u>1025 S Kroeger Ln, Tucson, AZ 85745</u>
_____	_____
_____	_____

Name and mailing address of each person who holds and claims the subject mining claim(s) for the valuable minerals contained therein. Be sure to indicate if there is a change of address:

Name (please print)	Current Mailing Address (please print)
<u>Keith A. Bown</u>	<u>1025 S. Kroeger Ln, Tucson, AZ 85745</u>
_____	_____
_____	_____
_____	_____
_____	_____
_____	_____
_____	_____
_____	_____

The undersigned testifies that on the date of April 1, 2015, all monuments required by law were erected upon the subject claim(s), and all notices required by law were posted on the subject claim(s) or copies thereof were in place, and at said date, each corner monument bore or contained

markings sufficient to appropriately designate the corner of the claim to which it pertains and the name of the claim(s).

I hereby certify under penalty of perjury under the laws of the State of Arizona that the foregoing statements are true and correct:

[Signature] Date: 10-19-15
(Signature of person responsible for above statement)

Title 18 U.S.C. 1001 and 43 U.S.C. 1212 make it a crime for any person knowingly and willfully to make to any department or agency of the United States any false, fictitious or fraudulent statements or representations as to any matter within its jurisdiction.

Notary Block

SUBSCRIBED AND SWORN TO before me, this 19 day of Oct 2015

By: [Signature]
(Signature of Affiant)

Title: Notary

My Commission Expires: Nov 1, 2017

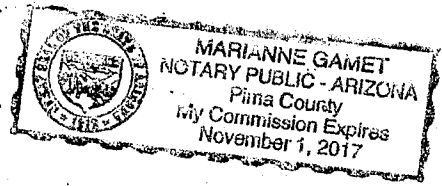

INSTRUCTIONS

1. This is an optional form that may be used to satisfy the requirements for the Bureau of Land Management (BLM) under the provisions of 43 U.S.C. §1744 and 30 U.S.C. §28-28d and the regulations thereunder (43 CFR part 3835). Since local and State laws may vary, you should contact your local and State agencies where the claims are located to ensure all applicable laws and requirements are satisfied.
2. The claimant(s) must fill in the date in paragraph 1 for the applicable assessment year and the county and state where the claims are located.
3. All claim names, BLM serial numbers, legal descriptions, and original county recording information must be listed for the claims pertaining to this assessment notice.
4. The claimant(s) must complete paragraph 2 listing all labor or improvements which was performed on or did benefit the subject mining claims. The value and date of the labor or improvements must also be listed. The total amount of labor or improvements can be listed, but the total expenditure must equal at least \$100 for each claim.
5. The names and current mailing addresses of the person(s) performing the labor shall be listed in paragraph 3.
6. The name and current mailing address of each owner (claimant) of the claims shall be listed in paragraph 4. The mailing address shall be the owner's address and not the address of an agent or anyone representing the claimant. Be sure to note if there has been a change of address.
7. Paragraph 5 shall be completed to show the date it was verified that all monuments required by law were properly erected, all notices were posted, and that corners were appropriately designated for all claims listed.
8. An exact legible reproduction or duplicate (other than microfilm or other electronic media) of this affidavit or another type of affidavit of assessment work that you file or will file in the county where each claim is located, must be filed with the BLM on or before December 30 of the calendar year in which the assessment year ends. For mill or tunnel sites, a separate notice of intent to hold must be filed with the BLM on or before December 30. Requirements for filing a notice of intent to hold can be found at 43 CFR 3835.33.
9. A processing fee of \$10 for each claim listed must be remitted to the BLM along with this or any other affidavit of assessment work.

(Continued on page 4)

ARIZONA
2015 DEC -2 A 10:53
RECEIVED
M A Z STATE OFFIC

(Form 3830-4, page 3)

UNITED STATES
DEPARTMENT OF THE INTERIOR
BUREAU OF LAND MANAGEMENT

FORM APPROVED
OMB NO.: 1004-0114
Expires: October 31, 2016

AFFIDAVIT OF ANNUAL ASSESSMENT WORK

WHEN RECORDED, MAIL DOCUMENT TO:

NAME: Keith H. Bowen

ADDRESS: 1025 S Kroeger Ln

CITY, STATE, ZIP: Tucson, AZ 85745

2015-05989
Page 1 of 4
Requested By: Keith H. Bowen
SUZANNE SAINZ, RECORDER
SANTA CRUZ COUNTY, ARIZONA
10-20-2015 11:36 AM Recording Fee \$15.00

FOR COUNTY RECORDER'S USE

No. of Claims 3

x \$10/claim

Total due BLM \$ 30.00

TO ALL WHOM IT MAY CONCERN:

1. The undersigned certifies that at least \$100 per claim was expended for development, labor and improvements, or equivalent value added, as the annual assessment work for the assessment year ending September 1, 2016 for the following contiguous unpatented mining claim(s), located in the County of Santa Cruz, in the State of ARIZONA.

BLM Serial No.	Name of Claim	Tp	Rg	Sec	Mer	County Description Book and Page No.	Date
		Example: 13N 5E 14 NDM					
403034	St Christopher #1	22S	10E	26	GSR	2010-08112	10-18-10
403035	St Christopher #2	22S	10E	26/35	GSR	2010-08113	10-18-10
403036	St Christopher #3	22S	10E	26	GSR	2010-08114	10-18-10

2015 DEC -2 A 10:53

2. Type of labor and improvements (specify what was done and give the total value for that labor and improvement to show at least \$100 for each claim). If a geological, geochemical, or geophysical survey was performed, as per 30 U.S.C. 28-1, reference the title of the report of survey, give cost and date of the survey and report, and indicate it was filed with the County Recorder:

Description of Work Performed	Value of Work Performed	Date Work Was Performed
Sampling	5300	1-28-15
Road Maintenance Inspection	100 25	1-28-15
Verify Monuments	100	1-28-15

3. Name and mailing address of each person who performed the labor and improvements:

Name (please print)

Keith A. Bown

Current Mailing Address (please print)

1025 S. Kroeger Ln, Tucson, AZ 85745

4. Name and mailing address of each person who holds and claims the subject mining claim(s) for the valuable minerals contained therein. Be sure to indicate if there is a change of address:

Name (please print)

Keith A. Bown

Current Mailing Address (please print)

1025 S. Kroeger Ln, Tucson, AZ 85745

5. The undersigned testifies that on the date of Jan 28, 2015, all monuments required by law were erected upon the subject claim(s), and all notices required by law were posted on the subject claim(s) or copies thereof were in place, and at said date, each corner monument bore or contained

markings sufficient to appropriately designate the corner of the claim to which it pertains and the name of the claim(s).

I hereby certify under penalty of perjury under the laws of the State of Arizona that the foregoing statements are true and correct:

[Signature]
(Signature of person responsible for above statement)

Date: 10-19-15

Title 18 U.S.C. 1001 and 43 U.S.C. 1212 make it a crime for any person knowingly and willfully to make to any department or agency of the United States any false, fictitious or fraudulent statements or representations as to any matter within its jurisdiction.

Notary Block

SUBSCRIBED AND SWORN TO before me, this 19 day of Oct 2015

By: [Signature]
(Signature of Affiant)

Title: Notary

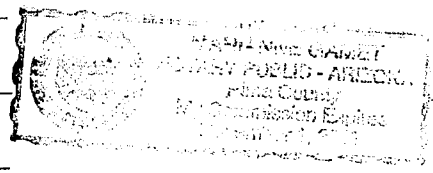

My Commission Expires: Nov 1, 2017

INSTRUCTIONS

1. This is an optional form that may be used to satisfy the requirements for the Bureau of Land Management (BLM) under the provisions of 43 U.S.C. §1744 and 30 U.S.C. §28-28d and the regulations thereunder (43 CFR part 3835). Since local and State laws may vary, you should contact your local and State agencies where the claims are located to ensure all applicable laws and requirements are satisfied.
2. The claimant(s) must fill in the date in paragraph 1 for the applicable assessment year and the county and state where the claims are located.
3. All claim names, BLM serial numbers, legal descriptions, and original county recording information must be listed for the claims pertaining to this assessment notice.
4. The claimant(s) must complete paragraph 2 listing all labor or improvements which was performed on or did benefit the subject mining claims. The value and date of the labor or improvements must also be listed. The total amount of labor or improvements can be listed, but the total expenditure must equal at least \$100 for each claim.
5. The names and current mailing addresses of the person(s) performing the labor shall be listed in paragraph 3.
6. The name and current mailing address of each owner (claimant) of the claims shall be listed in paragraph 4. The mailing address shall be the owner's address and not the address of an agent or anyone representing the claimant. Be sure to note if there has been a change of address.
7. Paragraph 5 shall be completed to show the date it was verified that all monuments required by law were properly erected, all notices were posted, and that corners were appropriately designated for all claims listed.
8. An exact legible reproduction or duplicate (other than microfilm or other electronic media) of this affidavit or another type of affidavit of assessment work that you file or will file in the county where each claim is located, must be filed with the BLM on or before December 30 of the calendar year in which the assessment year ends. For mill or tunnel sites, a separate notice of intent to hold must be filed with the BLM on or before December 30. Requirements for filing a notice of intent to hold can be found at 43 CFR 3835.331
9. A processing fee of \$10 for each claim listed must be remitted to the BLM along with this or any other affidavit of assessment work.

RECEIVED
BLM STATE OFFICE

NOTICES

THE PRIVACY ACT and 43 CFR 2.48(d) require that you be furnished with the following information in connection with the information requested by this form.

AUTHORITY: 30 U.S.C. §28-28d and 43 CFR part 3835 permit collection of the information requested by this form.

PRINCIPAL PURPOSE: The BLM will use the information you provide to document compliance with 43 U.S.C. 1744 and that assessment work has been completed in accordance with 30 U.S.C. § 28-28d and 43 CFR part 3835 in lieu of paying the maintenance fee for the mining claims listed on this form.

ROUTINE USES: The BLM will only disclose this information in accordance with the provisions at 43 CFR 2.56(b) and (c).

EFFECT OF NOT PROVIDING INFORMATION: Disclosure of the requested information is required by 30 U.S.C. § 28-28d and 43 CFR part 3835 for claimants qualified to perform assessment work in lieu of paying the maintenance fee. Failure to submit all the requested information or to complete this form will delay the BLM's processing of the form and may preclude the BLM's acceptance of the assessment work information, which may result in forfeiture of the mining claim(s) by the claimant.

THE PAPERWORK REDUCTION ACT requires us to inform you that:

Use of this form is optional. You must perform assessment if a waiver to pay the maintenance fee has been requested. This form is provided to help you attest that annual assessment work has been completed in lieu of paying the maintenance fee for your claim(s). Submission of the requested information is necessary to obtain or retain a benefit.

You do not have to respond to this or any other Federal agency-sponsored information collection unless it displays a valid OMB control number.

BURDEN HOURS STATEMENT: The estimated public reporting burden for this form is 30 minutes per response, including the time for reviewing instructions, gathering and maintaining data, and completing and reviewing the form. You may submit comments regarding the burden estimate or any other aspect of this form to: U.S. Department of the Interior, Bureau of Land Management (1004-0114), Bureau Information Collection Clearance Officer (WO-630), 1849 C Street, N.W., Room 2134LM, Washington, D.C. 20240.

United States Department of the Interior
Bureau of Land Management
 LANDS/RECREATION & PLANNING
 ONE N CENTRAL AVE
 PHOENIX, AZ 85004 -2203
 Phone: 602-417-9200

Receipt

No: 3444807

Transaction #: 3544168	
Date of Transaction: 12/02/2015	
CUSTOMER:	
KEITH H BOWEN 1025 S KROEGER LN TUCSON, AZ 85745-3070 US	

LINE #	QTY	DESCRIPTION	REMARKS	UNIT PRICE	TOTAL
1	1.00	LOCATABLE MINERALS / MINING CLAIMS- NOT NEW-UNADJUD, ONE AUTH NO. ONLY / MINING CLAIM MONEY RECEIVED CASES: AMC402998/\$290.00	POL (29)	- n/a -	290.00
TOTAL:					\$290.00

PAYMENT INFORMATION			
1	AMOUNT:	290.00	POSTMARKED: N/A
	TYPE:	CASH	RECEIVED: 12/02/2015
	NAME:	BOWEN, KEITH H 1025 S KROEGER LN TUCSON AZ 85745-3070 US	

REMARKS

This receipt was generated by the automated BLM Collections and Billing System and is a paper representation of a portion of the official electronic record contained therein.

100

402998

FORM APPROVED
OMB NO. 1004-0114
Expires: October 31, 2016

MAINTENANCE FEE WAIVER CERTIFICATION

SEE INSTRUCTIONS ON PAGE 2

1. This small miner waiver is filed for the assessment year beginning on September 1, 2015 and ending on September 1, 2016.
2. The undersigned and all related parties owned ten or fewer mining claims, mill, or tunnel sites located and maintained on Federal lands in the United States of America on September 1, 2015.
3. The undersigned have performed the assessment work required by law for each mining claim listed prior to filing this waiver and understand that by filing this form, the undersigned must file an affidavit of assessment work with the Bureau of Land Management (BLM) by the December 30th following the filing of this waiver.
4. The undersigned understand that if the assessment work obligation has not yet come due under 30 U.S.C. 28 (for those claims in their first assessment year only), a notice of intent to hold reciting this condition must be recorded by the December 30th following the filing of this waiver.
5. The undersigned understand that mill and tunnel sites may also be listed on this waiver and be waived from payment of the maintenance fee, and that a notice of intent to hold for these sites is required to be filed with the BLM by the December 30th following the filing of this waiver.
6. The undersigned understand and acknowledge that pursuant to 43 U.S.C. 1212 and 18 U.S.C. 1001, the filing or recording of a false, fictitious, or fraudulent document with the BLM may result in a fine of up to \$250,000, a prison term not to exceed five years, or both.
7. The mining claims, mill or tunnel sites for which this waiver from payment of the maintenance fees is requested are:

CLAIM OR SITE NAME	BLM RECORDATION SERIAL NUMBER
1. Good Enough E	AMC 402998
2. Good Enough W	AMC 402999
3. NYI-10	AMC 403000
4. NYI-20	AMC 403001
5. NYI-25	AMC 403002
6. NYI-26	AMC 403003
7. NYI-27	AMC 403004
8. NYI-28	AMC 403005
9. NYI-29	AMC 403006
10. NYI-35	AMC 403007

The owner(s) (claimants) of the above mining claims and sites are:

Charles R Bowen

(Owner's Name - Please Print)

(Owner's Signature)

2739 W Julie Ln

(Owner's Mailing Address)

Yuma

(City)

AZ

(State)

85365

(Zip Code)

(Owner's Name - Please Print)

(Owner's Signature)

(Owner's Mailing Address)

(City)

(State)

(Zip Code)

(Owner's Name - Please Print)

(Owner's Signature)

(Owner's Mailing Address)

(City)

(State)

(Zip Code)

(Owner's Name - Please Print)

(Owner's Signature)

(Owner's Mailing Address)

(City)

(State)

(Zip Code)

PHOENIX, ARIZONA
RECEIVED
BLM AZ STATE OFFICE
2015 JUL 22 A 11:51

ENTERED
SEP 2 2015
RE

NW-RE 9/2

402998
403018

KEITH BOWEN
1025 S KROEGER LN
TUCSON AZ 85745



MAIL
AMOUNT PAID: \$15.00

Form 3830-4
(October 2013)

UNITED STATES
DEPARTMENT OF THE INTERIOR
BUREAU OF LAND MANAGEMENT

FORM APPROVED
OMB NO.: 1004-0114
Expires: October 31, 2016

AFFIDAVIT OF ANNUAL ASSESSMENT WORK

WHEN RECORDED, MAIL DOCUMENT TO:

NAME: Keith H. Bowen
ADDRESS: 2015 S. Kroeger Ln
CITY, STATE, ZIP: Tucson, AZ
85745

RECEIVED
AZ STATE OFFICE
2014 DEC 19 A 9:02
PHOENIX, ARIZONA

FOR COUNTY RECORDER'S USE

No. of Claims 10
x \$10/claim
Total due BLM \$ 100

TO ALL WHOM IT MAY CONCERN:

1. The undersigned certifies that at least \$100 per claim was expended for development, labor and improvements, or equivalent value added, as the annual assessment work for the assessment year ending September 1, 2014 for the following contiguous unpatented mining claim(s), located in the County of Pima, in the State of Arizona.

BLM Serial No.	Name of Claim	Tp	Rg	Sec	Mer	County Recordation Book and Page No.	Date
^{AMC} 402998	Good Enough E	20S	10E	31	611.1 Self Div	D13916, P 893	10-18-2010
^{AMC} 402999	Good Enough W	20S	10E	31	"	D13916, P 895	10-18-2010
^{AMC} 403000	NY1-10	21S	10E	5	"	D13916, P 931	10-18-2010
^{AMC} 403001	NY1-20	21S	10E	5	"	D13916, P 947	10-18-2010
^{AMC} 403002	NY1-25	21S	10E	5	"	D13916, P 951	10-18-2010
^{AMC} 403003	NY1-26	21S	10E	5	"	D13916, P 953	10-18-2010
^{AMC} 403004	NY1-27	21S	10E	6	"	D13916, P 955	10-18-2010
^{AMC} 403005	NY1-28	21S	10E	6	"	D13916, P 957	10-18-2010
^{AMC} 403006	NY1-29	21S	10E	6	"	D13916, P 959	10-18-2010
^{AMC} 403007	NY1-35	21S	10E	5	"	D13916, P 961	10-18-2010

(Continued on page 2)

3193423
ENTERED
DEC 22 2014
BY: RAM

2. Type of labor and improvements (specify what was done and give the total value for that labor and improvement to show at least \$100 for each claim). If a geological, geochemical, or geophysical survey was performed, as per 30 U.S.C. 28-1, reference the title of the report of survey, give cost and date of the survey and report, and indicate it was filed with the County Recorder:

Description of Work Performed	Value of Work Performed	Date Work Was Performed
Bulk Sampling	\$1000	OCT 2013 - NOV 2013
Pilot Scale processing	\$1000	OCT 2013 - NOV 2013
check Monuments	\$500	OCT 2013 - NOV 2013
Build processing Equipment	\$4000	Dec 2013 - Jan 2014

3. Name and mailing address of each person who performed the labor and improvements:

Name (please print)

Keith H. Bowen
Matthew Hendry

Current Mailing Address (please print)

1025 S. Kroeger Ln, Tucson, AZ 85745
1025 S. Kroeger Ln, Tucson, AZ 85745

4. Name and mailing address of each person who holds and claims the subject mining claim(s) for the valuable minerals contained therein. Be sure to indicate if there is a change of address:

Name (please print)

Charles R. Bowen

Current Mailing Address (please print)

2739 W Julie Ln, Yuma, AZ 85365

5. The undersigned testifies that on the date of September 1, 2014, all monuments required by law were erected upon the subject claim(s), and all notices required by law were posted on the subject claim(s) or copies thereof were in place, and at said date, each corner monument bore or contained

W
 KEITH BOWEN
 1025 S KROEGER LN
 TUCSON AZ 85745



AFFPL 11/18/2014
 15:20
 MAIL
 AMOUNT PAID: \$15.00

Form 3830-4
 (October 2013)

UNITED STATES
 DEPARTMENT OF THE INTERIOR
 BUREAU OF LAND MANAGEMENT

FORM APPROVED
 OMB NO.: 1004-0114
 Expires: October 31, 2016

AFFIDAVIT OF ANNUAL ASSESSMENT WORK

WHEN RECORDED, MAIL DOCUMENT TO:

NAME: Keith H. Bowen
 ADDRESS: 1025 S Kroeger Ln
 CITY, STATE, ZIP: Tucson, AZ 85745

RECEIVED
 HAZ STATE OFFICE
 2014 DEC 19 A 9:02
 PHOENIX, ARIZONA

FOR COUNTY RECORDER'S USE

No. of Claims 7
 x \$10/claim
 Total due BLM \$ 70

TO ALL WHOM IT MAY CONCERN:

1. The undersigned certifies that at least \$100 per claim was expended for development, labor and improvements, or equivalent value added, as the annual assessment work for the assessment year ending September 1, 2014 for the following contiguous unpatented mining claim(s), located in the County of Pima, in the State of Arizona.

BLM Serial No.	Name of Claim	Tp	Rg	Sec	Mer	County Recordation Book and Page No.	Date
^{AMC} 403021	NY1-1	215	10E	4	61st SMT Rev	D13916, P 901	10-18-2010
^{AMC} 403022	NY1-2	215	10E	4	"	D13916, P 903	10-18-2010
^{AMC} 403023	NY1-6	215	10E	5	"	D13916, P 907	10-18-2010
^{AMC} 403024	NY1-7	215	10E	5	"	D13916, P 909	10-18-2010
^{AMC} 403027	NY1-13	215	10E	5	"	D13916, P 913	10-18-2010
^{AMC} 403031	NY1-21	215	10E	5	"	D13916, P 921	10-18-2010
^{AMC} 403018	Angelita	215	10E	8	"	D13916, P 897	10-18-2010
		215	10E		"		
		215	10E		"		
		215	10E		"		

2. Type of labor and improvements (specify what was done and give the total value for that labor and improvement to show at least \$100 for each claim). If a geological, geochemical, or geophysical survey was performed, as per 30 U.S.C. 28-1, reference the title of the report of survey, give cost and date of the survey and report, and indicate it was filed with the County Recorder:

Description of Work Performed	Value of Work Performed	Date Work Was Performed
Bank Sampling	\$1000	OCT 2013 - NOV 2013
Pilot Scale Processing	\$1000	OCT 2013 - NOV 2013
check MONUMENTS	\$500	OCT 2013 - NOV 2013
Build Processing Equipment	\$4000	Dec 2013 - Jan 2014

3. Name and mailing address of each person who performed the labor and improvements:

Name (please print)

Keith H. Bowa
Matthew Hendry

Current Mailing Address (please print)

1025 S. Kroeger Ln, Tucson, AZ 85745
1025 S. Kroeger Ln, Tucson, AZ 85745

4. Name and mailing address of each person who holds and claims the subject mining claim(s) for the valuable minerals contained therein. Be sure to indicate if there is a change of address:

Name (please print)

Keith H. Bowa

Current Mailing Address (please print)

1025 S. Kroeger Ln, Tucson, AZ 85745

Change of Address

5. The undersigned testifies that on the date of Sept 1, 2014, all monuments required by law were erected upon the subject claim(s), and all notices required by law were posted on the subject claim(s) or copies thereof were in place, and at said date, each corner monument bore or contained

KEITH BOWEN
1025 S KROEGER LN
TUCSON AZ 85745



AFFPL

11/18/2014

15:20

MAIL

AMOUNT PAID:

\$15.00

Form 3830-4
(October 2013)

UNITED STATES
DEPARTMENT OF THE INTERIOR
BUREAU OF LAND MANAGEMENT

FORM APPROVED
OMB NO.: 1004-0114
Expires: October 31, 2016

AFFIDAVIT OF ANNUAL ASSESSMENT WORK

WHEN RECORDED, MAIL DOCUMENT TO:

NAME: Keith H. Bowen

ADDRESS: 2015 S. Kroeger Ln

CITY, STATE, ZIP: Tucson, AZ
85745

RECEIVED
AZ STATE OFFICE
2014 DEC 19 A 9:02
PHOENIX, ARIZONA

FOR COUNTY RECORDER'S USE

No. of Claims 9

x \$10/claim

Total due BLM \$ 90

TO ALL WHOM IT MAY CONCERN:

1. The undersigned certifies that at least \$100 per claim was expended for development, labor and improvements, or equivalent value added, as the annual assessment work for the assessment year ending September 1, 2014 for the following contiguous unpatented mining claim(s), located in the County of Pima, in the State of AZ.

BLM Serial No.	Name of Claim	Tp	Rg	Sec	Mer	County Recordation Book and Page No.	Date
403019	Back Bone N	21S	10E	8	with Split Recd	Docket 13916, P 919	10-18-2010
403020	Back Bone S	21S	10E	8	"	D13916, P 919	"
^{AMC} 403025	NY1-11	21S	10E	5	"	D13916, P 933	"
^{AMC} 403026	NY1-12	21S	10E	5	"	D13916, P 935	"
^{AMC} 403028	NY1-16	21S	10E	8	"	D13916, P 915	"
^{AMC} 403029	NY1-17	21S	10E	8	x	D13916, P 917	"
^{AMC} 403030	NY1-18	21S	10E	8	"	D13916, P 941	"
^{AMC} 403032	NY1-22	21S	10E	5	"	D13916, P 949	"
^{AMC} 403033	NY1-23	21S	10E	8	"	D13916, P 923	"
					"		

2. Type of labor and improvements (specify what was done and give the total value for that labor and improvement to show at least \$100 for each claim). If a geological, geochemical, or geophysical survey was performed, as per 30 U.S.C. 28-1, reference the title of the report of survey, give cost and date of the survey and report, and indicate it was filed with the County Recorder:

Description of Work Performed	Value of Work Performed	Date Work Was Performed
Bank Sampling	\$1000	Oct 2013 - Nov 2013
Pilot Scale Processing	\$1000	Oct 2013 - Nov 2013
Check Monuments	\$500	Oct 2013 - Nov 2013
Build Processing Equipment	\$4000	Dec 2013 - Jan 2014

3. Name and mailing address of each person who performed the labor and improvements:

Name (please print)

Ruth H. Brown
Matthew Hendry

Current Mailing Address (please print)

1025 S. Kroeger Ln Tucson, AZ 85745
1025 S. Kroeger Ln Tucson, AZ 85745

4. Name and mailing address of each person who holds and claims the subject mining claim(s) for the valuable minerals contained therein. Be sure to indicate if there is a change of address:

Name (please print)

Eva J. Landry

Current Mailing Address (please print)

1025 S. Kroeger Ln Tucson, AZ 85745

(Change of Address)

5. The undersigned testifies that on the date of Sept 1, 2014, all monuments required by law were erected upon the subject claim(s), and all notices required by law were posted on the subject claim(s) or copies thereof were in place, and at said date, each corner monument bore or contained

markings sufficient to appropriately designate the corner of the claim to which it pertains and the name of the claim(s).

I hereby certify under penalty of perjury under the laws of the State of Arizona that the foregoing statements are true and correct:

[Signature] Date: 11-17-14
(Signature of person responsible for above statement)

Title 18 U.S.C. 1001 and 43 U.S.C. 1212 make it a crime for any person knowingly and willfully to make to any department or agency of the United States any false, fictitious or fraudulent statements or representations as to any matter within its jurisdiction.

Notary Block

SUBSCRIBED AND SWORN TO before me, this 17 day of November 2014

By: [Signature]
(Signature of Affiant)

Title: Notary Public

My Commission Expires: 2-24-17

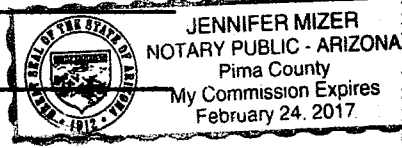

RECEIVED
BLM AZ STATE OFFICE
2014 DEC 19 A 9:02
PHOENIX, ARIZONA

INSTRUCTIONS

1. This is an optional form that may be used to satisfy the requirements for the Bureau of Land Management (BLM) under the provisions of 43 U.S.C. §1744 and 30 U.S.C. §28-28d and the regulations thereunder (43 CFR part 3835). Since local and State laws may vary, you should contact your local and State agencies where the claims are located to ensure all applicable laws and requirements are satisfied.
2. The claimant(s) must fill in the date in paragraph 1 for the applicable assessment year and the county and state where the claims are located.
3. All claim names, BLM serial numbers, legal descriptions, and original county recording information must be listed for the claims pertaining to this assessment notice.
4. The claimant(s) must complete paragraph 2 listing all labor or improvements which was performed on or did benefit the subject mining claims. The value and date of the labor or improvements must also be listed. The total amount of labor or improvements can be listed, but the total expenditure must equal at least \$100 for each claim.
5. The names and current mailing addresses of the person(s) performing the labor shall be listed in paragraph 3.
6. The name and current mailing address of each owner (claimant) of the claims shall be listed in paragraph 4. The mailing address shall be the owner's address and not the address of an agent or anyone representing the claimant. Be sure to note if there has been a change of address.
7. Paragraph 5 shall be completed to show the date it was verified that all monuments required by law were properly erected, all notices were posted, and that corners were appropriately designated for all claims listed.
8. An exact legible reproduction or duplicate (other than microfilm or other electronic media) of this affidavit or another type of affidavit of assessment work that you file or will file in the county where each claim is located, must be filed with the BLM on or before December 30 of the calendar year in which the assessment year ends. For mill or tunnel sites, a separate notice of intent to hold must be filed with the BLM on or before December 30. Requirements for filing a notice of intent to hold can be found at 43 CFR 3835.33.
9. A processing fee of \$10 for each claim listed must be remitted to the BLM along with this or any other affidavit of assessment work.

NOTICES

THE PRIVACY ACT and 43 CFR 2.48(d) require that you be furnished with the following information in connection with the information requested by this form.

AUTHORITY: 30 U.S.C. §28-28d and 43 CFR part 3835 permit collection of the information requested by this form.

PRINCIPAL PURPOSE: The BLM will use the information you provide to document compliance with 43 U.S.C. 1744 and that assessment work has been completed in accordance with 30 U.S.C. § 28-28d and 43 CFR part 3835 in lieu of paying the maintenance fee for the mining claims listed on this form.

ROUTINE USES: The BLM will only disclose this information in accordance with the provisions at 43 CFR 2.56(b) and (c).

EFFECT OF NOT PROVIDING INFORMATION: Disclosure of the requested information is required by 30 U.S.C. § 28-28d and 43 CFR part 3835 for claimants qualified to perform assessment work in lieu of paying the maintenance fee. Failure to submit all the requested information or to complete this form will delay the BLM's processing of the form and may preclude the BLM's acceptance of the assessment work information, which may result in forfeiture of the mining claim(s) by the claimant.

THE PAPERWORK REDUCTION ACT requires us to inform you that:

Use of this form is optional. You must perform assessment if a waiver to pay the maintenance fee has been requested. This form is provided to help you attest that annual assessment work has been completed in lieu of paying the maintenance fee for your claim(s). Submission of the requested information is necessary to obtain or retain a benefit.

You do not have to respond to this or any other Federal agency-sponsored information collection unless it displays a valid OMB control number.

BURDEN HOURS STATEMENT: The estimated public reporting burden for this form is 30 minutes per response, including the time for reviewing instructions, gathering and maintaining data, and completing and reviewing the form. You may submit comments regarding the burden estimate or any other aspect of this form to: U.S. Department of the Interior, Bureau of Land Management (1004-0114), Bureau Information Collection Clearance Officer (WO-630), 1849 C Street, N.W., Room 2134LM, Washington, D.C. 20240.

markings sufficient to appropriately designate the corner of the claim to which it pertains and the name of the claim(s).

I hereby certify under penalty of perjury under the laws of the State of Arizona that the foregoing statements are true and correct:

[Signature]

Date: 11-17-14

(Signature of person responsible for above statement)

Title 18 U.S.C. 1001 and 43 U.S.C. 1212 make it a crime for any person knowingly and willfully to make to any department or agency of the United States any false, fictitious or fraudulent statements or representations as to any matter within its jurisdiction.

Notary Block

SUBSCRIBED AND SWORN TO before me, this 17 day of November 2014

By: [Signature]
(Signature of Affiant)

Title: Notary Public

My Commission Expires: 2-24-17

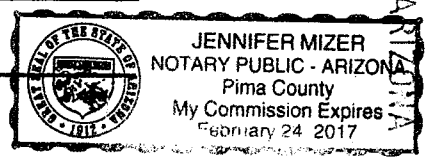

RECEIVED
AZ STATE OFFICE
NOENIX, ARIZONA
DEC 19 A 9: 02

INSTRUCTIONS

1. This is an optional form that may be used to satisfy the requirements for the Bureau of Land Management (BLM) under the provisions of 43 U.S.C. §1744 and 30 U.S.C. §28-28d and the regulations thereunder (43 CFR part 3835). Since local and State laws may vary, you should contact your local and State agencies where the claims are located to ensure all applicable laws and requirements are satisfied.
2. The claimant(s) must fill in the date in paragraph 1 for the applicable assessment year and the county and state where the claims are located.
3. All claim names, BLM serial numbers, legal descriptions, and original county recording information must be listed for the claims pertaining to this assessment notice.
4. The claimant(s) must complete paragraph 2 listing all labor or improvements which was performed on or did benefit the subject mining claims. The value and date of the labor or improvements must also be listed. The total amount of labor or improvements can be listed, but the total expenditure must equal at least \$100 for each claim.
5. The names and current mailing addresses of the person(s) performing the labor shall be listed in paragraph 3.
6. The name and current mailing address of each owner (claimant) of the claims shall be listed in paragraph 4. The mailing address shall be the owner's address and not the address of an agent or anyone representing the claimant. Be sure to note if there has been a change of address.
7. Paragraph 5 shall be completed to show the date it was verified that all monuments required by law were properly erected, all notices were posted, and that corners were appropriately designated for all claims listed.
8. An exact legible reproduction or duplicate (other than microfilm or other electronic media) of this affidavit or another type of affidavit of assessment work that you file or will file in the county where each claim is located, must be filed with the BLM on or before December 30 of the calendar year in which the assessment year ends. For mill or tunnel sites, a separate notice of intent to hold must be filed with the BLM on or before December 30. Requirements for filing a notice of intent to hold can be found at 43 CFR 3835.33.
9. A processing fee of \$10 for each claim listed must be remitted to the BLM along with this or any other affidavit of assessment work.

NOTICES

THE PRIVACY ACT and 43 CFR 2.48(d) require that you be furnished with the following information in connection with the information requested by this form.

AUTHORITY: 30 U.S.C. §28-28d and 43 CFR part 3835 permit collection of the information requested by this form.

PRINCIPAL PURPOSE: The BLM will use the information you provide to document compliance with 43 U.S.C. 1744 and that assessment work has been completed in accordance with 30 U.S.C. § 28-28d and 43 CFR part 3835 in lieu of paying the maintenance fee for the mining claims listed on this form.

ROUTINE USES: The BLM will only disclose this information in accordance with the provisions at 43 CFR 2.56(b) and (c).

EFFECT OF NOT PROVIDING INFORMATION: Disclosure of the requested information is required by 30 U.S.C. § 28-28d and 43 CFR part 3835 for claimants qualified to perform assessment work in lieu of paying the maintenance fee. Failure to submit all the requested information or to complete this form will delay the BLM's processing of the form and may preclude the BLM's acceptance of the assessment work information, which may result in forfeiture of the mining claim(s) by the claimant.

THE PAPERWORK REDUCTION ACT requires us to inform you that:

Use of this form is optional. You must perform assessment if a waiver to pay the maintenance fee has been requested. This form is provided to help you attest that annual assessment work has been completed in lieu of paying the maintenance fee for your claim(s). Submission of the requested information is necessary to obtain or retain a benefit.

You do not have to respond to this or any other Federal agency-sponsored information collection unless it displays a valid OMB control number.

BURDEN HOURS STATEMENT: The estimated public reporting burden for this form is 30 minutes per response, including the time for reviewing instructions, gathering and maintaining data, and completing and reviewing the form. You may submit comments regarding the burden estimate or any other aspect of this form to: U.S. Department of the Interior, Bureau of Land Management (1004-0114), Bureau Information Collection Clearance Officer (WO-630), 1849 C Street, N.W., Room 2134LM, Washington, D.C. 20240.

markings sufficient to appropriately designate the corner of the claim to which it pertains and the name of the claim(s).

I hereby certify under penalty of perjury under the laws of the State of ARIZONA that the foregoing statements are true and correct:

[Signature] Date: 11-17-14
(Signature of person responsible for above statement)

Title 18 U.S.C. 1001 and 43 U.S.C. 1212 make it a crime for any person knowingly and willfully to make to any department or agency of the United States any false, fictitious or fraudulent statements or representations as to any matter within its jurisdiction.

Notary Block

SUBSCRIBED AND SWORN TO before me, this 17 day of November 20 14

By: [Signature]
(Signature of Affiant)

Title: Notary Public

My Commission Expires: 2-24-17

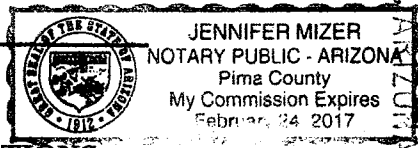

RECEIVED
AZ STATE OFFICE
2014 DEC 19 A 9:03
PHOENIX, ARIZONA

INSTRUCTIONS

1. This is an optional form that may be used to satisfy the requirements for the Bureau of Land Management (BLM) under the provisions of 43 U.S.C. §1744 and 30 U.S.C. §28-28d and the regulations thereunder (43 CFR part 3835). Since local and State laws may vary, you should contact your local and State agencies where the claims are located to ensure all applicable laws and requirements are satisfied.
2. The claimant(s) must fill in the date in paragraph 1 for the applicable assessment year and the county and state where the claims are located.
3. All claim names, BLM serial numbers, legal descriptions, and original county recording information must be listed for the claims pertaining to this assessment notice.
4. The claimant(s) must complete paragraph 2 listing all labor or improvements which was performed on or did benefit the subject mining claims. The value and date of the labor or improvements must also be listed. The total amount of labor or improvements can be listed, but the total expenditure must equal at least \$100 for each claim.
5. The names and current mailing addresses of the person(s) performing the labor shall be listed in paragraph 3.
6. The name and current mailing address of each owner (claimant) of the claims shall be listed in paragraph 4. The mailing address shall be the owner's address and not the address of an agent or anyone representing the claimant. Be sure to note if there has been a change of address.
7. Paragraph 5 shall be completed to show the date it was verified that all monuments required by law were properly erected, all notices were posted, and that corners were appropriately designated for all claims listed.
8. An exact legible reproduction or duplicate (other than microfilm or other electronic media) of this affidavit or another type of affidavit of assessment work that you file or will file in the county where each claim is located, must be filed with the BLM on or before December 30 of the calendar year in which the assessment year ends. For mill or tunnel sites, a separate notice of intent to hold must be filed with the BLM on or before December 30. Requirements for filing a notice of intent to hold can be found at 43 CFR 3835.33.
9. A processing fee of \$10 for each claim listed must be remitted to the BLM along with this or any other affidavit of assessment work.

NOTICES

THE PRIVACY ACT and 43 CFR 2.48(d) require that you be furnished with the following information in connection with the information requested by this form.

AUTHORITY: 30 U.S.C. §28-28d and 43 CFR part 3835 permit collection of the information requested by this form.

PRINCIPAL PURPOSE: The BLM will use the information you provide to document compliance with 43 U.S.C. 1744 and that assessment work has been completed in accordance with 30 U.S.C. § 28-28d and 43 CFR part 3835 in lieu of paying the maintenance fee for the mining claims listed on this form.

ROUTINE USES: The BLM will only disclose this information in accordance with the provisions at 43 CFR 2.56(b) and (c).

EFFECT OF NOT PROVIDING INFORMATION: Disclosure of the requested information is required by 30 U.S.C. § 28-28d and 43 CFR part 3835 for claimants qualified to perform assessment work in lieu of paying the maintenance fee. Failure to submit all the requested information or to complete this form will delay the BLM's processing of the form and may preclude the BLM's acceptance of the assessment work information, which may result in forfeiture of the mining claim(s) by the claimant.

THE PAPERWORK REDUCTION ACT requires us to inform you that:

Use of this form is optional. You must perform assessment if a waiver to pay the maintenance fee has been requested. This form is provided to help you attest that annual assessment work has been completed in lieu of paying the maintenance fee for your claim(s). Submission of the requested information is necessary to obtain or retain a benefit.

You do not have to respond to this or any other Federal agency-sponsored information collection unless it displays a valid OMB control number.

BURDEN HOURS STATEMENT: The estimated public reporting burden for this form is 30 minutes per response, including the time for reviewing instructions, gathering and maintaining data, and completing and reviewing the form. You may submit comments regarding the burden estimate or any other aspect of this form to: U.S. Department of the Interior, Bureau of Land Management (1004-0114), Bureau Information Collection Clearance Officer (WO-630), 1849 C Street, N.W., Room 2134LM, Washington, D.C. 20240.

UNITED STATES
DEPARTMENT OF THE INTERIOR
BUREAU OF LAND MANAGEMENT

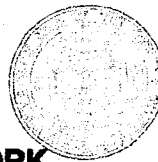

FORM APPROVED
OMB NO.: 1004-0114
Expires: October 31, 2016

AFFIDAVIT OF ANNUAL ASSESSMENT WORK

WHEN RECORDED, MAIL DOCUMENT TO:

NAME: Keith H. Bowen

ADDRESS: 1025 S. Kroeger Ln

CITY, STATE, ZIP: Tucson, AZ
85745

2014-06618

Page 1 of 4

Requested By: Keith H. Bowen

SUZANNE BAINZ, RECORDER

SANTA CRUZ COUNTY, ARIZONA

11-19-2014 10:32 AM Recording Fee \$15.00

RECEIVED
 M AZ STATE OFFICE
 2014 DEC 19 9A 9:03
 PHOENIX, ARIZONA

FOR COUNTY RECORDER'S USE

No. of Claims 30

x \$10/claim

Total due BLM \$ 300

TO ALL WHOM IT MAY CONCERN:

1. The undersigned certifies that at least \$100 per claim was expended for development, labor and improvements, or equivalent value added, as the annual assessment work for the assessment year ending September 1, 2014 for the following contiguous unpatented mining claim(s), located in the County of Santa Cruz, in the State of Arizona.

BLM Serial No.	Name of Claim	Tp	Rg	Sec	Mer	County Recordation Book and Page No.	Date
<u>AMC</u> 403034	<u>St Christopher #1</u>	<u>22S</u>	<u>10E</u>	<u>26</u>	<u>6 1/4 / Split Riv.</u>	<u>2010-08112</u>	<u>10-18-2010</u>
<u>AMC</u> 403035	<u>St Christopher #2</u>	<u>22S</u>	<u>10E</u>	<u>26/35</u>	<u>"</u>	<u>2010-08113</u>	<u>10-18-2010</u>
<u>AMC</u> 403036	<u>St Christopher #3</u>	<u>22S</u>	<u>10E</u>	<u>26</u>	<u>"</u>	<u>2010-08114</u>	<u>10-18-2010</u>

2. Type of labor and improvements (specify what was done and give the total value for that labor and improvement to show at least \$100 for each claim). If a geological, geochemical, or geophysical survey was performed, as per 30 U.S.C. 28-1, reference the title of the report of survey, give cost and date of the survey and report, and indicate it was filed with the County Recorder:

Description of Work Performed	Value of Work Performed	Date Work Was Performed
Bell Sampling	\$200	March 15, 2014
check monuments	\$200	March 16, 2014
Build Processing Equipment	\$4000	Dec 1 2013 to Jan 5 2014

3. Name and mailing address of each person who performed the labor and improvements:

Name (please print)	Current Mailing Address (please print)
<u>Keith H. Bown</u>	<u>1025 S. Kroeger Ln, Tucson, AZ 85745</u>
<u>Matthew Hendry</u>	<u>1025 S. Kroeger Ln, Tucson, AZ 85745</u>

4. Name and mailing address of each person who holds and claims the subject mining claim(s) for the valuable minerals contained therein. Be sure to indicate if there is a change of address:

Name (please print)	Current Mailing Address (please print)
<u>Keith H. Bown</u>	<u>1025 S. Kroeger Ln, Tucson, AZ 85745</u>
	<u>(change of Address)</u>

5. The undersigned testifies that on the date of Sept 1, 2014, all monuments required by law were erected upon the subject claim(s), and all notices required by law were posted on the subject claim(s) or copies thereof were in place, and at said date, each corner monument bore or contained

markings sufficient to appropriately designate the corner of the claim to which it pertains and the name of the claim(s).

I hereby certify under penalty of perjury under the laws of the State of Arizona that the foregoing statements are true and correct:

[Signature]

Date: 11-17-14

(Signature of person responsible for above statement)

Title 18 U.S.C. 1001 and 43 U.S.C. 1212 make it a crime for any person knowingly and willfully to make to any department or agency of the United States any false, fictitious or fraudulent statements or representations as to any matter within its jurisdiction.

Notary Block

SUBSCRIBED AND SWORN TO before me, this 17 day of November 2014

By: [Signature]
(Signature of Affiant)

Title: Notary Public

My Commission Expires: 2-24-17

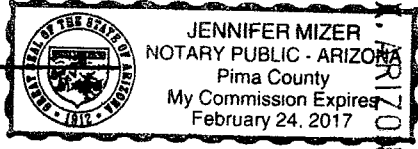

RECEIVED
BLM AZ STATE OFFICE
2014 DEC 19 A 9:03
PHOENIX, ARIZONA

INSTRUCTIONS

1. This is an optional form that may be used to satisfy the requirements for the Bureau of Land Management (BLM) under the provisions of 43 U.S.C. §1744 and 30 U.S.C. §28-28d and the regulations thereunder (43 CFR part 3835). Since local and State laws may vary, you should contact your local and State agencies where the claims are located to ensure all applicable laws and requirements are satisfied.
2. The claimant(s) must fill in the date in paragraph 1 for the applicable assessment year and the county and state where the claims are located.
3. All claim names, BLM serial numbers, legal descriptions, and original county recording information must be listed for the claims pertaining to this assessment notice.
4. The claimant(s) must complete paragraph 2 listing all labor or improvements which was performed on or did benefit the subject mining claims. The value and date of the labor or improvements must also be listed. The total amount of labor or improvements can be listed, but the total expenditure must equal at least \$100 for each claim.
5. The names and current mailing addresses of the person(s) performing the labor shall be listed in paragraph 3.
6. The name and current mailing address of each owner (claimant) of the claims shall be listed in paragraph 4. The mailing address shall be the owner's address and not the address of an agent or anyone representing the claimant. Be sure to note if there has been a change of address.
7. Paragraph 5 shall be completed to show the date it was verified that all monuments required by law were properly erected, all notices were posted, and that corners were appropriately designated for all claims listed.
8. An exact legible reproduction or duplicate (other than microfilm or other electronic media) of this affidavit or another type of affidavit of assessment work that you file or will file in the county where each claim is located, must be filed with the BLM on or before December 30 of the calendar year in which the assessment year ends. For mill or tunnel sites, a separate notice of intent to hold must be filed with the BLM on or before December 30. Requirements for filing a notice of intent to hold can be found at 43 CFR 3835.33.
9. A processing fee of \$10 for each claim listed must be remitted to the BLM along with this or any other affidavit of assessment work.

NOTICES

THE PRIVACY ACT and 43 CFR 2.48(d) require that you be furnished with the following information in connection with the information requested by this form.

AUTHORITY: 30 U.S.C. §28-28d and 43 CFR part 3835 permit collection of the information requested by this form.

PRINCIPAL PURPOSE: The BLM will use the information you provide to document compliance with 43 U.S.C. 1744 and that assessment work has been completed in accordance with 30 U.S.C. § 28-28d and 43 CFR part 3835 in lieu of paying the maintenance fee for the mining claims listed on this form.

ROUTINE USES: The BLM will only disclose this information in accordance with the provisions at 43 CFR 2.56(b) and (c).

EFFECT OF NOT PROVIDING INFORMATION: Disclosure of the requested information is required by 30 U.S.C. § 28-28d and 43 CFR part 3835 for claimants qualified to perform assessment work in lieu of paying the maintenance fee. Failure to submit all the requested information or to complete this form will delay the BLM's processing of the form and may preclude the BLM's acceptance of the assessment work information, which may result in forfeiture of the mining claim(s) by the claimant.

THE PAPERWORK REDUCTION ACT requires us to inform you that:

Use of this form is optional. You must perform assessment if a waiver to pay the maintenance fee has been requested. This form is provided to help you attest that annual assessment work has been completed in lieu of paying the maintenance fee for your claim(s). Submission of the requested information is necessary to obtain or retain a benefit.

You do not have to respond to this or any other Federal agency-sponsored information collection unless it displays a valid OMB control number.

BURDEN HOURS STATEMENT: The estimated public reporting burden for this form is 30 minutes per response, including the time for reviewing instructions, gathering and maintaining data, and completing and reviewing the form. You may submit comments regarding the burden estimate or any other aspect of this form to: U.S. Department of the Interior, Bureau of Land Management (1004-0114), Bureau Information Collection Clearance Officer (WO-630), 1849 C Street, N.W., Room 2134LM, Washington, D.C. 20240.

United States Department of the Interior
Bureau of Land Management
 LANDS/RECREATION & PLANNING
 ONE N CENTRAL AVE
 PHOENIX, AZ 85004 -2203
 Phone: 602-417-9200

Receipt

No: 3193423

Transaction #: 3286824	
Date of Transaction: 12/19/2014	
CUSTOMER:	
KEITH H BOWEN 1025 S KROEGER LN TUCSON, AZ 85745-3070 US	

LINE #	QTY	DESCRIPTION	REMARKS	UNIT PRICE	TOTAL
1	1.00	LOCATABLE MINERALS / MINING CLAIMS- NOT NEW-UNADJUD, ONE AUTH NO. ONLY / MINING CLAIM MONEY RECEIVED CASES: AMC402998/\$290.00	POL 2014/29	- n/a -	290.00
TOTAL:					\$290.00

PAYMENT INFORMATION					
1	AMOUNT:	290.00	POSTMARKED:	N/A	
	TYPE:	CASH	RECEIVED:	12/19/2014	
	NAME:	BOWEN, KEITH H 1025 S KROEGER LN TUCSON AZ 85745-3070 US			

REMARKS

This receipt was generated by the automated BLM Collections and Billing System and is a paper representation of a portion of the official electronic record contained therein.

ENTERED
 DEC 22 2014
 BY: *Rama*

UNITED STATES 276
DEPARTMENT OF THE INTERIOR
BUREAU OF LAND MANAGEMENT

MAINTENANCE FEE WAIVER CERTIFICATION

FORM APPROVED
OMB NO. 1004-0114
Expires: October 31, 2016

SEE INSTRUCTIONS ON PAGE 2

10/50

AMC 402998

- This small miner waiver is filed for the assessment year beginning on September 1, 2014 and ending on September 1, 2015.
- The undersigned and all related parties owned ten or fewer mining claims, mill, or tunnel sites located and maintained on Federal lands in the United States of America on September 1, 2014.
- The undersigned have performed the assessment work required by law for each mining claim listed prior to filing this waiver and understand that by filing this form, the undersigned must file an affidavit of assessment work with the Bureau of Land Management (BLM) by the December 30th following the filing of this waiver.
- The undersigned understand that if the assessment work obligation has not yet come due under 30 U.S.C. 28 (for those claims in their first assessment year only), a notice of intent to hold reciting this condition must be recorded by the December 30th following the filing of this waiver.
- The undersigned understand that mill and tunnel sites may also be listed on this waiver and be waived from payment of the maintenance fee, and that a notice of intent to hold for these sites is required to be filed with the BLM by the December 30th following the filing of this waiver.
- The undersigned understand and acknowledge that pursuant to 43 U.S.C. 1212 and 18 U.S.C. 1001, the filing or recording of a false, fictitious, or fraudulent document with the BLM may result in a fine of up to \$250,000, a prison term not to exceed five years, or both.
- The mining claims, mill or tunnel sites for which this waiver from payment of the maintenance fees is requested are:

CLAIM OR SITE NAME	BLM RECORDATION SERIAL NUMBER
1. Good Enough East	AMC 402998
2. Good Enough West	AMC 402999
3. NY1-10	AMC 403000
4. NY1-20	AMC 403001
5. NY1-25	AMC 403002
6. NY1-26	AMC 403003
7. NY1-27	AMC 403004
8. NY1-28	AMC 403005
9. NY1-29	AMC 403006
10. NY1-35	AMC 403007

The owner(s) (claimants) of the above mining claims and sites are:

Charles R Bowen ✓
(Owner's Name - Please Print)

[Signature]
(Owner's Signature)

2739 W Julie Ln
(Owner's Mailing Address)

Yuma AZ 85365
(City) (State) (Zip Code)

(Owner's Name - Please Print)

(Owner's Signature)

(Owner's Mailing Address)

ENTERED
AC 483
SEP 11 2014
BY: RB

(City) (State) (Zip Code)

(Owner's Name - Please Print)

(Owner's Signature)

(Owner's Mailing Address)

(City) (State) (Zip Code)

(Owner's Name - Please Print)

(Owner's Signature)

(Owner's Mailing Address)

(City) (State) (Zip Code)

SEP 11 2014
(Continued on page 2)
NW-check (10)
RB

(Owner's Name - Please Print)

(Owner's Signature)

(Owner's Mailing Address)

(City)

(State)

(Zip Code)

(Owner's Name - Please Print)

(Owner's Signature)

(Owner's Mailing Address)

(City)

(State)

(Zip Code)

(Owner's Name - Please Print)

(Owner's Signature)

(Owner's Mailing Address)

(City)

(State)

(Zip Code)

(Owner's Name - Please Print)

(Owner's Signature)

(Owner's Mailing Address)

(City)

(State)

(Zip Code)

18 U.S.C. 1001 and 43 U.S.C. 1212 make it a crime for any person knowingly and willfully to make to any department or agency of the United States any false, fictitious or fraudulent statements or representations as to any matter within its jurisdiction.

INSTRUCTIONS

1. This certification is made under the provisions of 43 U.S.C. § 1744 and 30 U.S.C. §28-28k and the regulations thereunder (43 CFR Part 3830).
2. The claimant(s) must fill in the dates in paragraph 1 for the beginning and ending of the assessment year for which this waiver is sought.
3. The claimant(s) must fill in the date in paragraph 2 for the beginning of the assessment year for which this waiver is sought.
4. All claim and site names and BLM serial numbers must be listed for the mining claims, mill sites, and tunnel sites for which the waiver is sought.
5. All owners of the mining claims, mill sites, and tunnel sites and their addresses must be given.
6. This waiver form must be signed by all the claimants or their designated agent, in original form. If an agent is designated, a notarized designation of agent, signed by all of the claimants with proper address given, must be submitted with this waiver.
7. This form must be filed no later than September 1st for the upcoming assessment year in the BLM State Office where the mining claims or sites are recorded, or the waiver cannot be granted by the BLM. (Example: To obtain a waiver for the assessment year 2012, which begins on September 1, 2011, you must qualify for and file for a waiver no later than September 1, 2011, in the proper BLM State Office.)
8. For all mining claims which require assessment work, you must record an affidavit of labor on or before the December 30th immediately following the filing of this waiver. For all other mining claims or sites waived, you must record a notice of intent to hold on or before the December 30th immediately following the filing of this waiver.
9. Mill and tunnel sites may also be listed on this waiver and be waived from payment of the maintenance fee. A notice of intent to hold for these sites is required to be filed by the December 30th following the filing of this waiver.

RECEIVED
 BLM AZ STATE OFFICE
 2014 AUG 15 P 12:56
 PHOENIX, ARIZONA

FOR OFFICIAL USE ONLY

UNITED STATES DEPARTMENT OF THE INTERIOR
BUREAU OF LAND MANAGEMENT

MC NATIONWIDE CLAIMANT LISTING
September 11, 2014

Cust	AZ CLAIMANT	National Total
BOWEN CHARLES R 2739 W JULIE LN YUMA, AZ 85365-8054	10	10

Run Time: 11:14 AM

Department of the Interior
Bureau of Land Management
Public Land Statistics

Run Date: 09/11/2014

Nationwide Claimant Listing
(Mining Claim Only)

Selection Criteria

System Id = MC

Cust Nm Begins With BOWEN CHARLES R

Loc Dt Between

Address Begins With

City Begins With

State Begins With

Case Disp = A

Total Rows Returned: 10

BLM
Date
Stamp

RECEIVED
BLM AZ STATE OFFICE
2013 DEC 27 A 11 48
PHOENIX, ARIZONA

7	403004	NY1-27	D13916, Pg 955	215	10E	8
8	403005	NY1-28	D13916, Pg 957	215	10E	6
9	403006	NY1-29	D13916, Pg 959	215	10E	6
10	403007	NY1-35	D13916, Pg 961	215	10E	5

6. That between the dates starting at 12 o'clock noon on September 1, 20 12 and ending at 12 o'clock noon on September 1, 20 13 at least \$ 2000.00 dollars worth of work and improvements were done and performed upon said claim(s) or upon one or more of a contiguous group of claims for the benefit of all, wholly or partly outside of a contiguous group of claims for the benefit of all, not including the location work.

7. That the following persons were employed to perform the work and improvements described herein: Keith Bawn, Eva Landay, Matthew Henday

8. That the work and improvements performed were: bulk sampling, metallurgical analysis, Road repair, purchase & build mill equipment

9. Dated: 9-30-13 Signature: [Signature]

SUBSCRIBED AND SWORN TO before me, a Notary Public, this 30th day of SEPT. 20 13

By: Keith H. Bawn

Notary Public Joana Santiago

My Commission Expires 6-12-2015

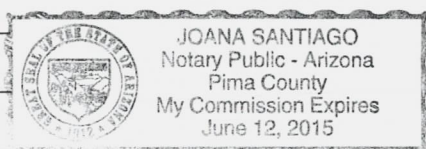

Bureau of Land Management
Arizona State Office
www.az.blm.gov

No. of Claims: 10 x \$10 = 100.00
 Check No.: CASH Init. [Signature]
 Receipt No.: 2937780
 For BLM Use Only

United States Department of the Interior
Bureau of Land Management
 LANDS/RECREATION & PLANNING
 ONE N CENTRAL AVE
 PHOENIX, AZ 85004 -2203
 Phone: 602-417-9200

Receipt

No: 2937780

Transaction #: 3025397	
Date of Transaction: 12/27/2013	
CUSTOMER:	
CHARLES R BOWEN 2739 W JULIE LN YUMA, AZ 85365-8054 US	

LINE #	QTY	DESCRIPTION	REMARKS	UNIT PRICE	TOTAL
1	1.00	LOCATABLE MINERALS / MINING CLAIMS- NOT NEW-UNADJUD, ONE AUTH NO. ONLY / MINING CLAIM MONEY RECEIVED CASES: AMC402998/\$100.00	POL (10)	- n/a -	100.00
TOTAL:					\$100.00

PAYMENT INFORMATION			
1	AMOUNT:	100.00	POSTMARKED: N/A
	TYPE:	CASH	RECEIVED: 12/27/2013
	NAME:	BOWEN, KEITH 765 W LIMBERLOST DR APT 33 TUCSON AZ 85705	

REMARKS

This receipt was generated by the automated BLM Collections and Billing System and is a paper representation of a portion of the official electronic record contained therein.



SEQUENCE: 20122890236
 NO. PAGES: 2
 AFFPL 10/15/2012
 14:50
 MAIL
 AMOUNT PAID: \$15.00

W
 KEITH BOWEN
 765 W LIMBERLOST DR 33
 TUCSON AZ 85705

E-mail address: _____

Amc 402998

AFFIDAVIT OF PERFORMANCE OF ANNUAL WORK

1. State of Arizona, County of Pima ss:
 2 I (Name) Keith H. Bowen
 3 Reside at (Address) 765 W Limberlost Dr
APT 33
 City Tucson County Pima

RECEIVED
 BLM AZ STATE OFFICE
 PHOENIX, ARIZONA
 2012 DEC - 7 P 12: 15
 BLM
 Date
 Stamp

State AZ Zip 85705 being duly sworn, depose and say that I am a citizen of the United States, more than eighteen years of age, and that all of the facts set forth in this affidavit, subject to the provisions and penalties of 18 U.S.C 1001 pertaining to the filing of false, fictitious, or fraudulent statements with the United States, are true and correct according to the best of my knowledge, information and belief.

4 Owner's name and address (if not shown in Items 1-3 above). Charles R Bowen
2739 W Julie Ln, Yuma, AZ 85365

5. That I am personally acquainted with the mining claim(s). The work and improvements were made by and at the expense of the owner(s) of said claim(s). Said contiguous group of claims, listed on this document, are situated in the

Las Guijas (optional) Mining District; Pima County, Arizona.

Line No	AMC NUMBER	CLAIM/SITE NAME	COUNTY RECORDER DATA (If available)	TWP	RNG	SEC
1	402998	Good Enough E	Docket 13916 Pg 943	T20S	R10E	31
2	402999	Good Enough W	" 13916 Pg 945	T20S	R10E	31
3	403000	NY1-10	" 13916 Pg 931	T21S	R10E	5
4	403001	NY1-20	" 13916 Pg 947	T21S	R10E	5
5	403002	NY1-25	" 13916 Pg 951	T21S	R10E	5
6	403003	NY1-26	" 13916 Pg 953	T21S	R10E	5

ENTERED INTO COMPUTER

1/9/13 AT

RECEIVED
BLM STATE OFFICE
PHOENIX, ARIZONA
2012 DEC - 7 P 12:15
BLM
Date
Stamp

7	403004	NYI - 27	Docket 13916 P, 955 T215	RIDE	6
8	403005	NYI - 28	" 13916 P, 957 T215	RIDE	6
9	403006	NYI - 29	" 13916 P, 959 T215	RIDE	6
10	403007	NYI - 35	" 13916 P, 961 T215	RIDE	5

6 That between the dates starting at 12 o'clock noon on September 1, 20 11 and ending at 12 o'clock noon on September 1, 20 12 at least \$ 2000.00 dollars worth of work and improvements were done and performed upon said claim(s) or upon one or more of a contiguous group of claims for the benefit of all, wholly or partly outside of a contiguous group of claims for the benefit of all, not including the location work.

7 That the following persons were employed to perform the work and improvements described herein: Keith Bower, Dillon Landry, Matthew Hendry

8 That the work and improvements performed were: road maintenance, tunnel cleaning, ground control, bulk sampling, metallurgical testing

9 Dated: 10-11-12 Signature: [Signature]

SUBSCRIBED AND SWORN TO before me, a Notary Public, this 11th day of October 2012

By: Keith Bower

Notary Public [Signature]

My Commission Expires 10/1/15

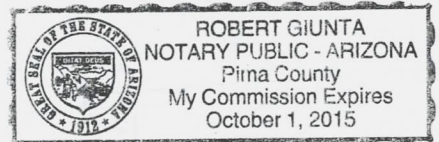

Bureau of Land Management
Arizona State Office
www.az.blm.gov

No. of Claims: 10 x \$10 = 100.00
Check No.: CASH Init. [Signature]
Receipt No.: 2704029
For BLM Use Only

Form: MCF108
Revised Jan. 2006
Page 2 of 2

**United States Department of the Interior
Bureau of Land Management
LANDS/RECREATION & PLANNING
ONE N CENTRAL AVE
PHOENIX, AZ 85004 -2203
Phone: 602-417-9200**

Receipt

No: 2704029

Transaction #: 2786022	ENTERED INTO COMPUTER
Date of Transaction: 12/07/2012	
CUSTOMER:	
CHARLES R BOWEN 2739 W JULIE LN YUMA, AZ 85365-8054 US	

LINE #	QTY	DESCRIPTION	REMARKS	UNIT PRICE	TOTAL
1	1.00	LOCATABLE MINERALS / MINING CLAIMS- NOT NEW-UNADJUD, ONE AUTH NO. ONLY / MINING CLAIM MONEY RECEIVED CASES: AMC402998/\$100.00	2012 POL (10)	- n/a -	100.00
TOTAL:					\$100.00

PAYMENT INFORMATION			
1	AMOUNT:	100.00	POSTMARKED: N/A
	TYPE:	CASH	RECEIVED: 12/07/2012
	NAME:	BOWEN, KEITH AZ US	

REMARKS

This receipt was generated by the automated BLM Collections and Billing System and is a paper representation of a portion of the official electronic record contained therein.

Amc 402998

UNITED STATES
DEPARTMENT OF THE INTERIOR
BUREAU OF LAND MANAGEMENT

not
10

FORM APPROVED
OMB NO. 1004-0114
Expires: February 28, 2010

206

MAINTENANCE FEE WAIVER CERTIFICATION

SEE INSTRUCTIONS ON PAGE 2

2012 TS

2013 TS

1. This small miner waiver is filed for the assessment year beginning at noon on September 1, ~~2011~~ and ending at noon on September 1, 2012
2. The undersigned and all related parties owned ten or fewer mining claims, mill, or tunnel sites located and maintained on Federal lands in the United States of America on September 1, 2012
3. The undersigned have performed the assessment work required by law for each mining claim listed prior to filing this waiver and understand that by filing this form; an affidavit of assessment work must be recorded by the December 30th following the filing of this waiver.
4. The undersigned understand that if the assessment work obligation has not yet come due under 30 U.S.C. 28 (for those claims in their first assessment year only); a notice of intent to hold reciting this condition must be recorded by the December 30th following the filing of this waiver.
5. The undersigned understand that mill and tunnel sites may also be listed upon this waiver and be waived from payment of the maintenance fee; and that a notice of intent to hold for these sites is required to be recorded by the December 30th immediately following the filing of this waiver.
6. The undersigned understand and acknowledge that pursuant to 43 U.S.C. 1212 and 18 U.S.C. 1001; the filing or recording of a false, fictitious, or fraudulent document with the Bureau of Land Management may result in a fine of up to \$250,000, a prison term not to exceed five years, or both.
7. The mining claims, mill or tunnel sites for which this waiver from payment of the maintenance fees is requested are:

CLAIM OR SITE NAME	BLM RECORDATION SERIAL NUMBER
1. Good Enough East	AMC 402998 L
2. Good Enough West	AMC 402999
3. NYI-10	AMC 403000
4. NYI-20	AMC 403001
5. NYI-25	AMC 403002
6. NYI-26	AMC 403003
7. NYI-27	AMC 403004
8. NYI-28	AMC 403005
9. NYI-29	AMC 403006
10. NYI-35	AMC 403007

The owner(s) (claimants) of the above mining claims and sites are:

Charles R Bowen

(Owner's Name - Please Print)

[Signature]
(Owner's Signature)

2739
2239 W Julie Ln

(Street or P.O. Box)

Yuma AZ 85365
(City) (State) (Zip Code)

(Owner's Name - Please Print)

(Street or P.O. Box)

(City) (State) (Zip Code)

(Owner's Name - Please Print)

(Street or P.O. Box)

(City) (State) (Zip Code)

RECEIVED
BLM AZ STATE OFFICE
2012 AUG 13 P 3:59
PHOENIX, ARIZONA

8/29/2012 TS
ENTERED INTO COMPUTER

January 26, 2012



U.S. Dept. of the Interior
Bureau of Land Management
1 N. Central Ave. #800
Phoenix, AZ

In Reply to: 3800 (9310) AT
AMC402998- AMC403007

Concerning CMRR#7011 2970 0001 8020 7717

To Whom It May Concern:

These ten claims are mine to do with as I see fit. Keith Bowen, my brother, does not control them or exercise any control on my claims or vice versa. Though the four claim owners mentioned in your inquiry are acquainted and may work cooperatively at times, that is all. As for the question of money and paperwork, since Keith lives in the county and has the time to turn in paperwork to the county and to the Dept. of the Interior, he was asked to do so. If this is a problem, I will personally take care of this in the future. Also, the reason all paperwork and checks were filed last year under Keith's name was that he failed to file the paperwork in time and volunteered to make it right. This will not happen again.

If you have any questions, please call me at, 520-907-9445.

Sincerely,

Charles Bowen

RECEIVED
BLM AZ REGIONAL OFFICE
2012 JAN 30 PM 2:07
PHOENIX, ARIZONA

CALIFORNIA JURAT WITH AFFIANT STATEMENT

- See Attached Document (Notary to cross out lines 1-6 below)
 See Statement Below (Lines 1-5 to be completed only by document signer[s], *not* Notary)

Signature of Document Signer No. 1

Signature of Document Signer No. 2 (if any)

RECEIVED
BLM A7
2012 JAN 30 PM 2:07
PHOENIX, ARIZONA

State of California

County of Imperial

Subscribed and sworn to (or affirmed) before me on this

27th day of January, 2012, by
Date Month Year

(1) Charles Bowen
Name of Signer

proved to me on the basis of satisfactory evidence to be the person who appeared before me (.) (,)

(and)

(2) _____
Name of Signer

proved to me on the basis of satisfactory evidence to be the person who appeared before me.)

Signature Debra A Baro
Signature of Notary Public

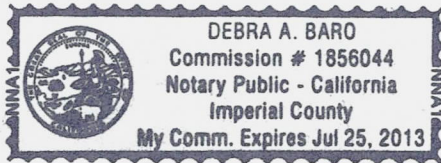

Place Notary Seal Above

OPTIONAL

Though the information below is not required by law, it may prove valuable to persons relying on the document and could prevent fraudulent removal and reattachment of this form to another document.

Further Description of Any Attached Document

Title or Type of Document: U.S. Dept. of the Interior

Document Date: 01/26/2012 Number of Pages: one

Signer(s) Other Than Named Above: None

RIGHT THUMBPRINT
OF SIGNER #1
Top of thumb here

RIGHT THUMBPRINT
OF SIGNER #2
Top of thumb here



SEQUENCE: 20112900713
 NO. PAGES: 2
 AFFPL 10/17/2011 18:00
 PICK UP
 AMOUNT PAID: \$14.00

MAIL
 KEITH BOWEN
 PICKUP

Amc 402998
 Amc 403008
 Amc 403018

E-mail address: Gold West Rattle Run@hotmail.com

AFFIDAVIT OF PERFORMANCE OF ANNUAL WORK

1. State of Arizona, County of Pima ss:
 2. I (Name) Keith A. Bowen
 3. Reside at (Address) 765 W Lumberlost Dr, Apt 33
 City Tucson County Pima

RECEIVED
 PHOENIX STATE OFFICE
 2011 DEC 13 P 3:54
 PHOENIX, ARIZONA
 BLM
 Date
 Stamp

State AZ Zip 85705 being duly sworn, depose and say that I am a citizen of the United States, more than eighteen years of age, and that all of the facts set forth in this affidavit, subject to the provisions and penalties of 18 U.S.C. 1001 pertaining to the filing of false, fictitious, or fraudulent statements with the United States, are true and correct according to the best of my knowledge, information and belief.

4. Owner's name and address (If not shown in Items 1-3 above). Charles R. Bowen
2739^W Julie Ln, Yuma, AZ 85365

5. That I am personally acquainted with the mining claim(s). The work and improvements were made by and at the expense of the owner(s) of said claim(s). Said contiguous group of claims, listed on this document, are situated in the Las Guijas (optional) Mining District; Pima County, Arizona.

Line No.	AMC NUMBER	CLAIM/SITE NAME	COUNTY RECORDER DATA (If available)	TWP	RNG	SEC
1	402998	Good Enough E	13916-893	20S	10E	31
2	402999	Good Enough W	13916-895	"	"	31
3	403000	NY1-10	13916-931	21S	10E	5
4	403001	NY1-20	13916-947	"	"	5
5	403002	NY1-25	13916-951	"	"	5
6	403003	NY1-26	13916-953	"	"	5

ENTERED INTO COMPUTER

1/4/12 AT

2

RECEIVED
BLM AZ STATE OFFICE

2011 DEC 13 P 3:54

BLM
Date
Stamp
PHOENIX, ARIZONA

7	403004	NY1-27	13916-955	215	10E	6
8	403005	NY1-28	13916-957	"	"	6
9	403006	NY1-29	13916-959	"	"	6
10	403007	NY1-35	13916-961	"	"	5

6. That between the dates starting at 12 o'clock noon on September 1, 20 10 and ending at 12 o'clock noon on September 1, 20 11 at least \$ 2000.00 dollars worth of work and improvements were done and performed upon said claim(s) or upon one or more of a contiguous group of claims for the benefit of all, wholly or partly outside of a contiguous group of claims for the benefit of all, not including the location work.

7. That the following persons were employed to perform the work and improvements described herein: Keith Bower, Eva Lowday, Dillon Lowday, Tom Parrish, Matthew Hendry

8. That the work and improvements performed were: road clearing, tunnel clearing, barring down, Timbering, metallurgical analyses, geochemical analyses

9. Dated: 10-12-11 Signature: [Signature]

SUBSCRIBED AND SWORN TO before me, a Notary Public, this 12 day of 11 20 11

By: [Signature]

Notary Public Ram mehta

My Commission Expires Apr 27, 2015

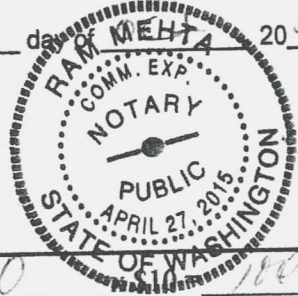

No. of Claims: 10 100
 Check No.: CASH Init. [Init]
 Receipt No.: 2481854
 For BLM Use Only

Bureau of Land Management
 Arizona State Office
www.az.blm.gov



SEQUENCE: 20112900714
 NO. PAGES: 2
 AFFPL 10/17/2011 18:00
 PICK UP
 AMOUNT PAID: \$14.00

MAIL
 KEITH BOWEN
 PICKUP

E-mail address: wildwest100th@comcast.net

AFFIDAVIT OF PERFORMANCE OF ANNUAL WORK

1. State of Arizona, County of Pima ss:

2. I (Name) Keith H. Bowen

3. Reside at (Address) 765 W Limberlost Dr, Apt 33

City Tucson County Pima

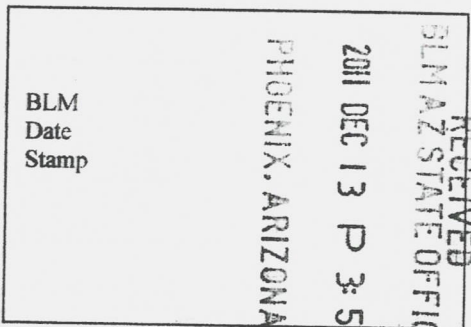

State Az zip 85705 being duly sworn, depose and say that I am a citizen of the United States, more than eighteen years of age, and that all of the facts set forth in this affidavit, subject to the provisions and penalties of 18 U.S.C. 1001 pertaining to the filing of false, fictitious, or fraudulent statements with the United States, are true and correct according to the best of my knowledge, information and belief.

4. Owner's name and address (If not shown in Items 1-3 above). Eva J. Landry
765 W Limberlost Dr, Apt 33, Tucson, AZ 85705

5. That I am personally acquainted with the mining claim(s). The work and improvements were made by and at the expense of the owner(s) of said claim(s). Said contiguous group of claims, listed on this document, are situated in the

La Guijas (optional) Mining District; Pima County, Arizona.

Line No.	AMC NUMBER	CLAIM/SITE NAME	COUNTY RECORDER DATA (If available)	TWP	RNG	SEC
1	403019	Back Bone N	13916 - 919	21S	10E	8
2	403020	Back Bone S	13916 - 894	"	"	8
3	403025	NY1-11	13916 - 933	"	"	5
4	403026	NY1-12	13916 - 935	"	"	5
5	403028	NY1-16	13916 - 915	"	"	8
6	403029	NY1-17	13916 - 917	"	"	8

RECEIVED
 BLM AZ STATE OFFICE
 PHOENIX, ARIZONA
 2011 DEC 13 P 3:54
 BLM
 Date
 Stamp

7	403030	NYI-18	13916-941	2LS	10E	8
8	403032	NYI-22	13916-949	"	"	5
9	403033	NYI-23	13916-923	"	"	8
10						

6. That between the dates starting at 12 o'clock noon on September 1, 20 10 and ending at 12 o'clock noon on September 1, 20 11 at least \$ 2000.00 dollars worth of work and improvements were done and performed upon said claim(s) or upon one or more of a contiguous group of claims for the benefit of all, wholly or partly outside of a contiguous group of claims for the benefit of all, not including the location work.

7. That the following persons were employed to perform the work and improvements described herein: Eva Lowrey, Keith Bown, Dillon Lowrey, Anthony Feddermao, Matthew Hendry

8. That the work and improvements performed were: road repairs, tunnel clearing, timbering, metallurgical analysis

9. Dated: 10-12-11 Signature: [Signature]

SUBSCRIBED AND SWORN TO before me, a Notary Public, this 12 day of Dec, 20 11

By: [Signature]
 Notary Public Ram Mehta

My Commission Expires Apr 27, 2015

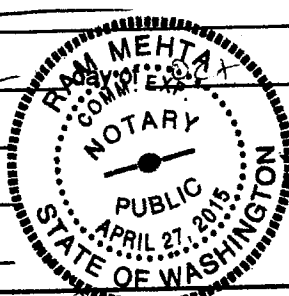

No. of Claims: 9 x \$10 = 90
 Check No.: CASH Init. [Initialed]
 Receipt No.: 2481852
 For BLM Use Only

Bureau of Land Management
 Arizona State Office
www.az.blm.gov

When Recorded Return Document to:

Keith Bowen
765 W Kimberlost Dr, Apt 33
Tucson, AZ 85705

2011-07048
Page 1 of 2
Requested By: Keith Bowen
SUZANNE SAINZ, RECORDER
SANTA CRUZ COUNTY, ARIZONA
10-25-2011 12:25 PM Recording Fee \$19.00

Check here if this is a change of address.

Telephone: 520-631-6523

E-mail address: wildwestkettlecorn@hotmail.com

AFFIDAVIT OF PERFORMANCE OF ANNUAL WORK

- 1. State of Arizona, County of Santa Cruz ss:
- 2. I (Name) Keith H. Bowen
- 3. Reside at (Address) 765 W Kimberlost Dr,
Apt 33
- City Tucson County Pima

RECEIVED
 BLM AZ STATE OFFICE
 PHOENIX, ARIZONA
 2011 DEC 13 P 3:54
 BLM
 Date
 Stamp

State AZ Zip 85705 being duly sworn, depose and say that I am a citizen of the United States, more than eighteen years of age, and that all of the facts set forth in this affidavit, subject to the provisions and penalties of 18 U.S.C. 1001 pertaining to the filing of false, fictitious, or fraudulent statements with the United States, are true and correct according to the best of my knowledge, information and belief.

4. Owner's name and address (If not shown in Items 1-3 above). Keith Bowen, same

5. That I am personally acquainted with the mining claim(s). The work and improvements were made by and at the expense of the owner(s) of said claim(s). Said contiguous group of claims, listed on this document, are situated in the

Oro Blanco (optional) Mining District; Santa Cruz County, Arizona.

Line No.	AMC NUMBER	CLAIM/SITE NAME	COUNTY RECORDER DATA (If available)	TWP	RNG	SEC
1	403034	ST Christopher #1	2010-08112	22S	10E	26
2	403035	ST Christopher #2	2010-08113	"	"	26/35
3	403036	ST Christopher #3	2010-08114	"	"	26
4						
5						
6						

AFFIDAVIT OF PERFORMANCE OF ANNUAL WORK - page 2

RECEIVED
 PHOENIX, ARIZONA
 2011 DEC 13 P 3:54
 BLM
 Date
 Stamp

7						
8						
9						
10						

6. That between the dates starting at 12 o'clock noon on September 1, 20 10 and ending at 12 o'clock noon on September 1, 20 11 at least \$ 600.00 dollars worth of work and improvements were done and performed upon said claim(s) or upon one or more of a contiguous group of claims for the benefit of all, wholly or partly outside of a contiguous group of claims for the benefit of all, not including the location work.

7. That the following persons were employed to perform the work and improvements described herein: Keith Bowen, Evan Lownday, Dillon Lownday

8. That the work and improvements performed were: road work, geochemical testing, metallurgical testing,

9. Dated: 10-12-11 Signature: [Signature]

SUBSCRIBED AND SWORN TO before me, a Notary Public, this 12 day of Dec

By: Ram Mehta

Notary Public Ram Mehta

My Commission Expires Apr 27, 2015

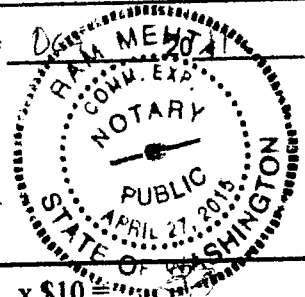

Bureau of Land Management
 Arizona State Office
 www.az.blm.gov

No. of Claims: 3 x \$10 =
 Check No.: CASH Init. [Signature]
 Receipt No.: 2481854
 For BLM Use Only



MAIL
 KEITH BOWEN
 PICKUP

E-mail address: wildwestkethkern@hotmail.com

AFFIDAVIT OF PERFORMANCE OF ANNUAL WORK

1. State of Arizona, County of Pima ss:
 2. I (Name) Keith A. Bowen
 3. Reside at (Address) 765 W Limberlost Dr, Apt 33
 City Tucson County Pima

RECEIVED
 PIMA STATE OFFICE
 PHOENIX, ARIZONA
 2011 DEC 13 P 3:58
 BLM
 Date
 Stamp

State AZ Zip 85705 being duly sworn, depose and say that I am a citizen of the United States, more than eighteen years of age, and that all of the facts set forth in this affidavit, subject to the provisions and penalties of 18 U.S.C. 1001 pertaining to the filing of false, fictitious, or fraudulent statements with the United States, are true and correct according to the best of my knowledge, information and belief.

4. Owner's name and address (If not shown in Items 1-3 above). Keith Bowen, same

5. That I am personally acquainted with the mining claim(s). The work and improvements were made by and at the expense of the owner(s) of said claim(s). Said contiguous group of claims, listed on this document, are situated in the

Las Guijas (optional) Mining District; Pima County, Arizona.

Line No.	AMC NUMBER	CLAIM/SITE NAME	COUNTY RECORDER DATA (If available)	TWP	RNG	SEC
1	403021	NY1-1	13916-901	21S	10E	4
2	403022	NY1-2	13916-903	"	"	4
3	403023	NY1-6	13916-907	"	"	5
4	403024	NY1-7	13916-909	"	"	5
5	403027	NY1-13	13916-913	"	"	5
6	403031	NY1-21	13916-921	"	"	5

BLM
Date
Stamp

2011 DEC 13 P 3:53
PHOENIX ARIZONA

RECEIVED
ARIZONA STATE OFFICE

7	403018	Angelita	13916-897	215	10E	8
8						
9						
10						

6. That between the dates starting at 12 o'clock noon on September 1, 20 10 and ending at 12 o'clock noon on September 1, 20 11 at least \$ 1400.00 dollars worth of work and improvements were done and performed upon said claim(s) or upon one or more of a contiguous group of claims for the benefit of all, wholly or partly outside of a contiguous group of claims for the benefit of all, not including the location work.

7. That the following persons were employed to perform the work and improvements described herein: Keith Bowen, Eva Landry, Dillon Landry, Ryan Landry, Tom Parrish

8. That the work and improvements performed were: Road Improvement, Clearing Tunnels, Barring Down, Timbering, Metallurgical Testing, geochemical testing

9. Dated: 10-12-11 Signature: [Signature]

SUBSCRIBED AND SWORN TO before me, a Notary Public, this 12 day of Dec 2011

By: [Signature]
Notary Public Ram mehta

My Commission Expires Apr 27, 2015

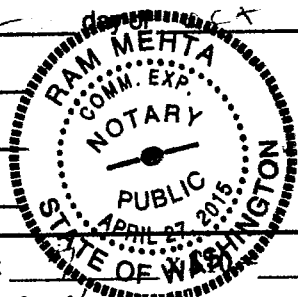

No. of Claims: 70
 Check No.: CASH Init. [Initials]
 Receipt No.: 2481854
 For BLM Use Only

Bureau of Land Management
Arizona State Office
www.az.blm.gov



SEQUENCE: 20112900712
 NO. PAGES: 2
 AFFPL 10/17/2011 18:00
 PICK UP
 AMOUNT PAID: \$14.00

MAIL
 KEITH BOWEN
 PICKUP

E-mail address: wildwestkettlekorn@hotmail.com

AFFIDAVIT OF PERFORMANCE OF ANNUAL WORK

1. State of Arizona, County of Pima ss:
 2. I (Name) Keith H. Bowen
 3. Reside at (Address) 765 W Lumberlost Dr
APT 33
 City Tucson County Pima

RECEIVED
 BLM AZ STATE OFFICE
 2011 DEC 13 P 3:53
 PHOENIX, ARIZONA
 BLM Date Stamp

State AZ Zip 85705 being duly sworn, depose and say that I am a citizen of the United States, more than eighteen years of age, and that all of the facts set forth in this affidavit, subject to the provisions and penalties of 18 U.S.C. 1001 pertaining to the filing of false, fictitious, or fraudulent statements with the United States, are true and correct according to the best of my knowledge, information and belief.

4. Owner's name and address (If not shown in Items 1-3 above). Ray Deere
36250 Lazy Arc Trails, P.O. Box 95, Arivaca, AZ 85601

5. That I am personally acquainted with the mining claim(s). The work and improvements were made by and at the expense of the owner(s) of said claim(s). Said contiguous group of claims, listed on this document, are situated in the Las Guijas (optional) Mining District; Pima County, Arizona.

Line No.	AMC NUMBER	CLAIM/SITE NAME	COUNTY RECORDER DATA (If available)	TWP	RNG	SEC
1	403008	NY1-3	13916, 905	21S	10E	4
2	403009	NY1-4	" 925	"	"	4
3	403010	NY1-5	" 927	"	"	4
4	403011	NY1-8	" 911	"	"	5
5	403012	NY1-9	" 929	"	"	5
6	403013	NY1-14	" 937	"	"	5

BLM
Date
Stamp

PHOENIX, ARIZONA

2011 DEC 13 P 3:54

RECEIVED
BLM AZ STATE OFFICE

7	403014	NY1-15	13916,	939	215	10E	5
8	403015	NY1-19	"	945	215	"	5
9	403016	NY1-36	"	963	215	"	5
10	403017	NY1-37	"	943	215	"	5

6. That between the dates starting at 12 o'clock noon on September 1, 20 10 and ending at 12 o'clock noon on September 1, 20 11 at least \$ 2,000.00 dollars worth of work and improvements were done and performed upon said claim(s) or upon one or more of a contiguous group of claims for the benefit of all, wholly or partly outside of a contiguous group of claims for the benefit of all, not including the location work.

7. That the following persons were employed to perform the work and improvements described herein: Kirtz Bower, Eva Landry, Matthew Hendry, Dillon Landry

8. That the work and improvements performed were: road repairs, tunnel clearing, equipment purchase, timbering, geochemical analysis

9. Dated: 10-12-11 Signature: [Signature]

SUBSCRIBED AND SWORN TO before me, a Notary Public, this 12 day of October 2011

By: Ram Mehta

Notary Public Ram mehta

My Commission Expires 04/27/2015

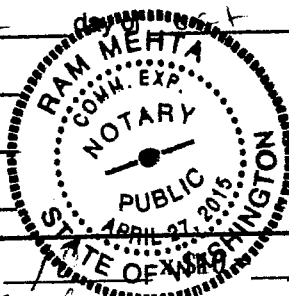

No. of Claims: 103

Check No.: 6090 Init. [Initials]

Receipt No.: 2481854

For BLM Use Only

Bureau of Land Management
Arizona State Office
www.blm.gov

United States Department of the Interior
 Bureau of Land Management
 LANDS/RECREATION & PLANNING
 ONE N CENTRAL AVE
 PHOENIX, AZ 85004 -2203
 Phone: 602-417-9200



Receipt

No:

2481854

Transaction #: 2558451	
Date of Transaction: 12/14/2011	
CUSTOMER:	
KEITH BOWEN 1501 S CLOVERLAND AVE TUCSON, AZ 85711-5432 US	

LINE #	QTY	DESCRIPTION	REMARKS	UNIT PRICE	TOTAL
1	1.00	LOCATABLE MINERALS / MINING CLAIMS-NOT NEW-UNADJUD, ONE AUTH NO. ONLY / MINING CLAIM MONEY RECEIVED CASES: AMC403021/\$390.00	POL 2011/39	- n/a -	390.00
TOTAL:					\$390.00

PAYMENT INFORMATION			
1	AMOUNT:	390.00	POSTMARKED: N/A
	TYPE:	CASH	RECEIVED: 12/14/2011
	NAME:	BOWEN, KEITH 1501 S CLOVERLAND AVE TUCSON AZ 85711-5432 US	

REMARKS

This receipt was generated by the automated BLM Collections and Billing System and is a paper representation of a portion of the official electronic record contained therein.

UNITED STATES
DEPARTMENT OF THE INTERIOR
BUREAU OF LAND MANAGEMENT

Amc 402998

EAG

FORM APPROVED
OMB NO. 1004 0114
Expires: August 31, 2013

456

- This small miner waiver is filed for the assessment year beginning on September 1, 2011 and ending on September 1, 2012.
- The undersigned and all related parties owned ten or fewer mining claims, mill, or tunnel sites located and maintained on Federal lands in the United States of America on September 1, 2011.
- The undersigned have performed the assessment work required by law for each mining claim listed prior to filing this waiver and understand that by filing this form, an affidavit of assessment work must be recorded by the December 30th following the filing of this waiver.
- The undersigned understand that if the assessment work obligation has not yet come due under 30 U.S.C. 28 (for those claims in their first assessment year only), a notice of intent to hold reciting this condition must be recorded by the December 30th following the filing of this waiver.
- The undersigned understand that mill and tunnel sites may also be listed upon this waiver and be waived from payment of the maintenance fee, and that a notice of intent to hold for these sites is required to be recorded by the December 30th immediately following the filing of this waiver.
- The undersigned understand and acknowledge that pursuant to 43 U.S.C. 1212 and 18 U.S.C. 1001, the filing or recording of a false, fictitious, or fraudulent document with the Bureau of Land Management may result in a fine of up to \$250,000, a prison term not to exceed five years, or both.
- The mining claims, mill or tunnel sites for which this waiver from payment of the maintenance fees is requested are:

CLAIM OR SITE NAME	BLM RECORDATION SERIAL NUMBER
1. Good Enough E	✓ AMC 4029 98
2. Good Enough W	AMC 4029 99
3. NYI 10	AMC 4030 00
4. NYI 20	AMC 4030 01
5. NYI 25	AMC 4030 02
6. NYI 26	AMC 4030 03
7. NYI 27	AMC 4030 04
8. NYI 28	AMC 4030 05
9. NYI 29	AMC 4030 06
10. NYI 35	AMC 4030 07

The owner(s) (claimants) of the above mining claims and sites are:

(Owner's Name Please Print)
 Charles R Bowen
 (Street or P.O. Box)
 2739 Julie Lane
 (City) Yuma (State) AZ (Zip Code) 85365

(Owner's Signature)

(Owner's Name Please Print)

(Owner's Signature)

(Street or P.O. Box)

(City)

(State)

(Zip Code)

(Owner's Name Please Print)

(Owner's Signature)

(Street or P.O. Box)

(City)

(State)

(Zip Code)

PHOENIX, ARIZONA

2011 AUG 25 P 3:34

BLM AZ STATE OFFICE

RECEIVED

NOTICE!!

These documents have been scanned!

Do not place un-scanned documents beneath this notice!

Do not remove this notice from this file!

GPO Jacket No. 560-102
Print Order 61540
Rise Business Services, LLC
Job=AZ15 5/17/2019



Box Number= AZ15063



Claim Begin-End: AMC402998-AMC403007

6 Location Notices-Amendments and Supporting Documents



AZ15063-8

AMC402730-AMC403264

MINING CLAIM STATUS REPORT

DATA ENTERED **ENTERED INTO COMPUTER**

MTP Checked by _____

GEO Checked by _____

LEAD SERIAL NUMBER 12-6-10 cm AMC 403998 thru AMC 403007

OF CLAIMS & TYPE

CHARGES

# <u>10</u> LODE	Location Fee @ \$34 = \$ <u>340</u>
# _____ PLACER	Processing Fee @ \$15 = \$ <u>150</u>
# _____ ASSOCIATION PLACER	Maintenance Fee @ \$140 = \$ <u>1400</u>
# _____ MILL SITE	Overage (+) \$ _____
# _____ TUNNEL SITE	Shortage (-) \$ _____
	Other Fees \$ _____
	TOTAL \$ <u>1890</u>

ARE THERE ENOUGH LOCATORS?

Yes () No () _____

DOCUMENTS RECEIVED VIA -

Over-the-Counter () Mail ()

TIMELY FILED?

Yes () No ()

*38
claims all
together filed
appropriately.*

LEGAL DESCRIPTION -	T	<u>20S</u>	R	<u>10E</u>	SEC	<u>31</u>
	T	<u>21S</u>	R	<u>10E</u>	SEC	<u>5,6</u>
	T	_____	R	_____	SEC	_____
	T	_____	R	_____	SEC	_____

BLM () FOREST SERVICE () _____ SUBJ TO PL 359: Yes () No ()

WILDERNESS AREA: No () Yes () _____

SPLIT ESTATE - N/A () SX () PX () SRHA () OTHER () _____

Proper Notice Filed if Located on SHRA Lands? N/A () Yes () No ()

RECONVEYED MINERALS ON BLM LANDS REQUIRE OPENING ORDERS FROM 1944 TO 1993 -

Open to Entry on: _____ N/A ()

COMMENTS/STATUS - VOID () PARTIALLY VOID () PVT MINERALS () WITHDRAWN LANDS ()

OTHER () AMC 403007 the west part may be on Acquired land not open to location

Claimant acknowledges that portions of the following claims(s) site(s) may be void or voidable.

Printed Name of Claimant _____ Signature of Claimant _____

***** FINAL ADJUDICATION *****

DATE 4/19/2011 INITIALS TJ

AMC 402998

F. ANN RODRIGUEZ, ORDER
RECORDED BY: JCC
DEPUTY RECORDER
0305 PE6-4351



DOI: 13916
PAGE: 893
NO. OF PAGES: 2
SEQUENCE: 20102000361
10/18/2010
LOCATN 16:05
MAIL
AMOUNT PAID \$ 10.00

W
KEITH BOWEN
PO BOX 18275
TUCSON AZ 85731

LOCATION NOTICE FOR LODE MINING CLAIM

NOTICE IS HEREBY GIVEN that the Good Enough East
_____ lode mining claim has been located
by Charles R. Bowen whose current mailing
address is 2739 Julie Lane
Yuma, AZ 85365

RECORDED
BLM AS STAFF OFFICE
2010 NOV 17 A 11: 52
TUCSON, AZ
BLM
Date
Stamp

The general course of this claim is East to West and it is situated in Pima
County, Arizona. This claim is 1500 feet in length and 600 feet in width. This claim runs
from the location monument on which this location notice is posted approximately 10 feet in a
westerly direction to the west end line and 1490 feet in a easterly direction to the
east end line. This claim is marked by six monuments, one at each corner and one at the center of each
end line of the claim.

The location monument on which this notice is posted is situated within Section 31, Township 20
South, Range 10 East, Gila Salt River Base and Meridian, Arizona and this claim encompasses portions
of the following quarter section (s), section (s), Township (s) and Range (s) NW 1/4, Sect 31,
T 20S, R 10E
Gila Salt River Base and Meridian, Arizona.

The locality of this claim with reference to some natural object or permanent monument and additional information
(if any) concerning its locality are as follows: the location monument is about
1500' E and 950' S of the NW corner of
sect 31, T 20S, R 10E

DATED AND POSTED on the ground this 21 day of Sept, 2010.
LOCATOR (s) Keith H. Bowen For Charles R. Bowen
KBH

Form MCF100
Revised July 2005

AMC 402998

40-10 2007

MINING CLAIM MAP

Lode (X) Placer ()

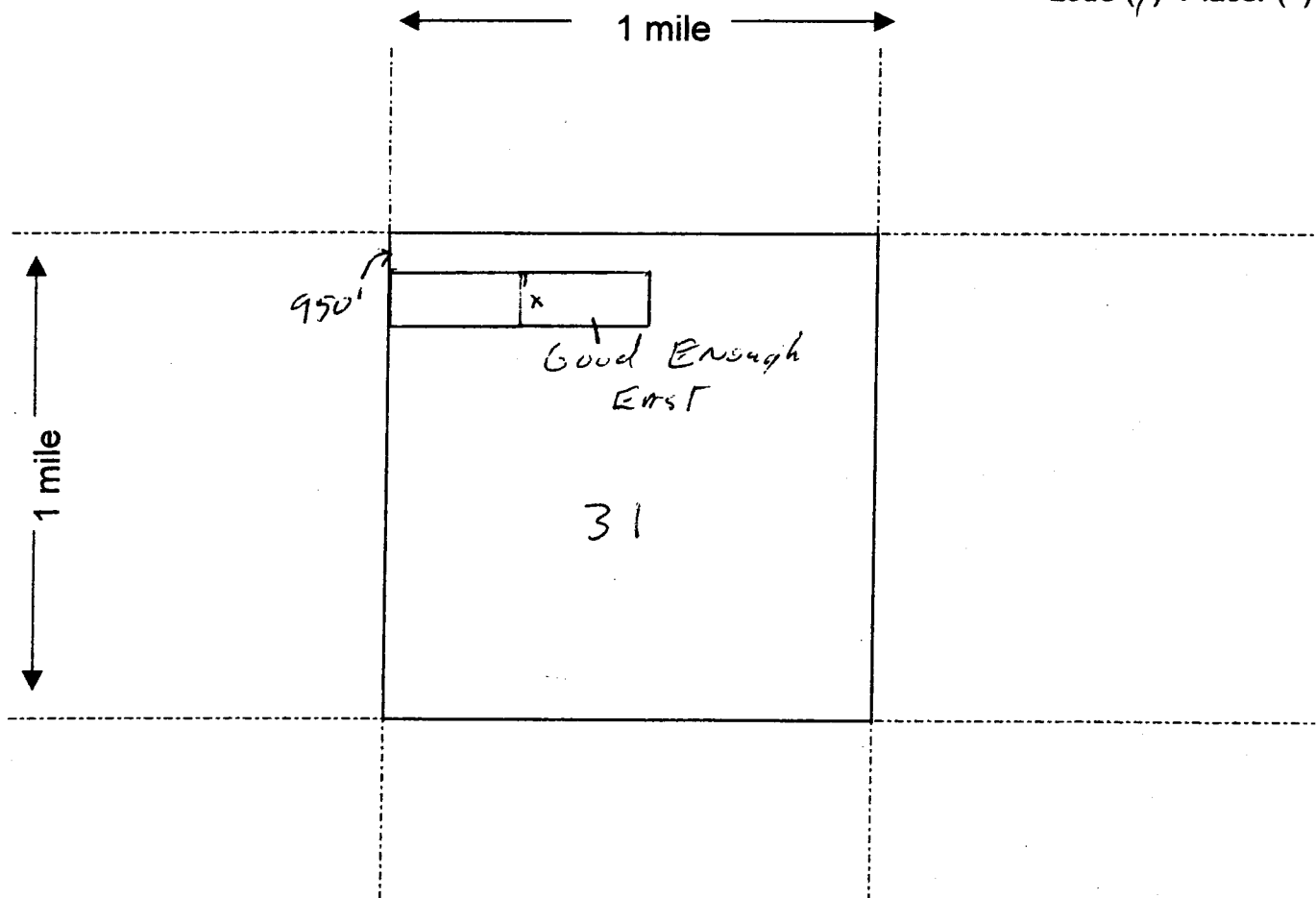

Scale : 1" = 2000 feet



1. The above map depicts the Good Enough E mining claim, which is located in Section (s) 31, Township 20S, Range 10 EAST, Gila and Salt River Base and Meridian, Pima County, Arizona.
2. The type of corner and location monuments used are as follows: 2x2 wood
3. The bearings and distances in degrees and feet between claim corners are as depicted on the map.

Form MCF100a
Revised July 2005

This form is available from the Arizona Department of Mines & Mineral Resources and may be reproduced.

1-0010 020004

F. ANN RODRIGUEZ, ORDER
RECORDED BY: JCC
DEPUTY RECORDER
0305 PE6-4351



DOC : 13916
PAGE : 895
NO. OF PAGES: 2
SEQUENCE: 20102000362
LOCATN 10/18/2010 16:05
MAIL
AMOUNT PAID \$ 10.00

W
KEITH BOWEN
PO BOX 18275
TUCSON AZ 85731

LOCATION NOTICE FOR LODE MINING CLAIM

NOTICE IS HEREBY GIVEN that the Good Enough West
_____ lode mining claim has been located
by Charles R. Bowen whose current mailing
address is 2739 Julie Ln
Yuma, AZ 85365

RECORDED
PIMA COUNTY OFFICE
2010 NOV 17 A 11:52
PIMA, AZ
BLM
Date
Stamp

The general course of this claim is EAST to WEST and it is situated in Pima
County, Arizona. This claim is 1500 feet in length and 600 feet in width. This claim runs
from the location monument on which this location notice is posted approximately 10 feet in a
easterly direction to the EAST end line and 1490 feet in a westerly direction to the
WEST end line. This claim is marked by six monuments, one at each corner and one at the center of each
end line of the claim.

The location monument on which this notice is posted is situated within Section 31, Township 20
South, Range 10 EAST, Gila Salt River Base and Meridian, Arizona and this claim encompasses portions
of the following quarter section (s), section (s), Township (s) and Range (s) NW 1/4, Sect 31,
T20S, R10E

Gila Salt River Base and Meridian, Arizona.

The locality of this claim with reference to some natural object or permanent monument and additional information
(if any) concerning its locality are as follows: the location monument is about
1500' east and 950' south of the NW corner
of section 31, T20S, R10E

DATED AND POSTED on the ground this 21 day of Sept, 2010.

LOCATOR (s) Keith H. Bowen for Charles R Bowen
KB

Form MCF100
Revised July 2005

AMC 402999

10-10 2000

✓

MINING CLAIM MAP

Lode (X) Placer ()

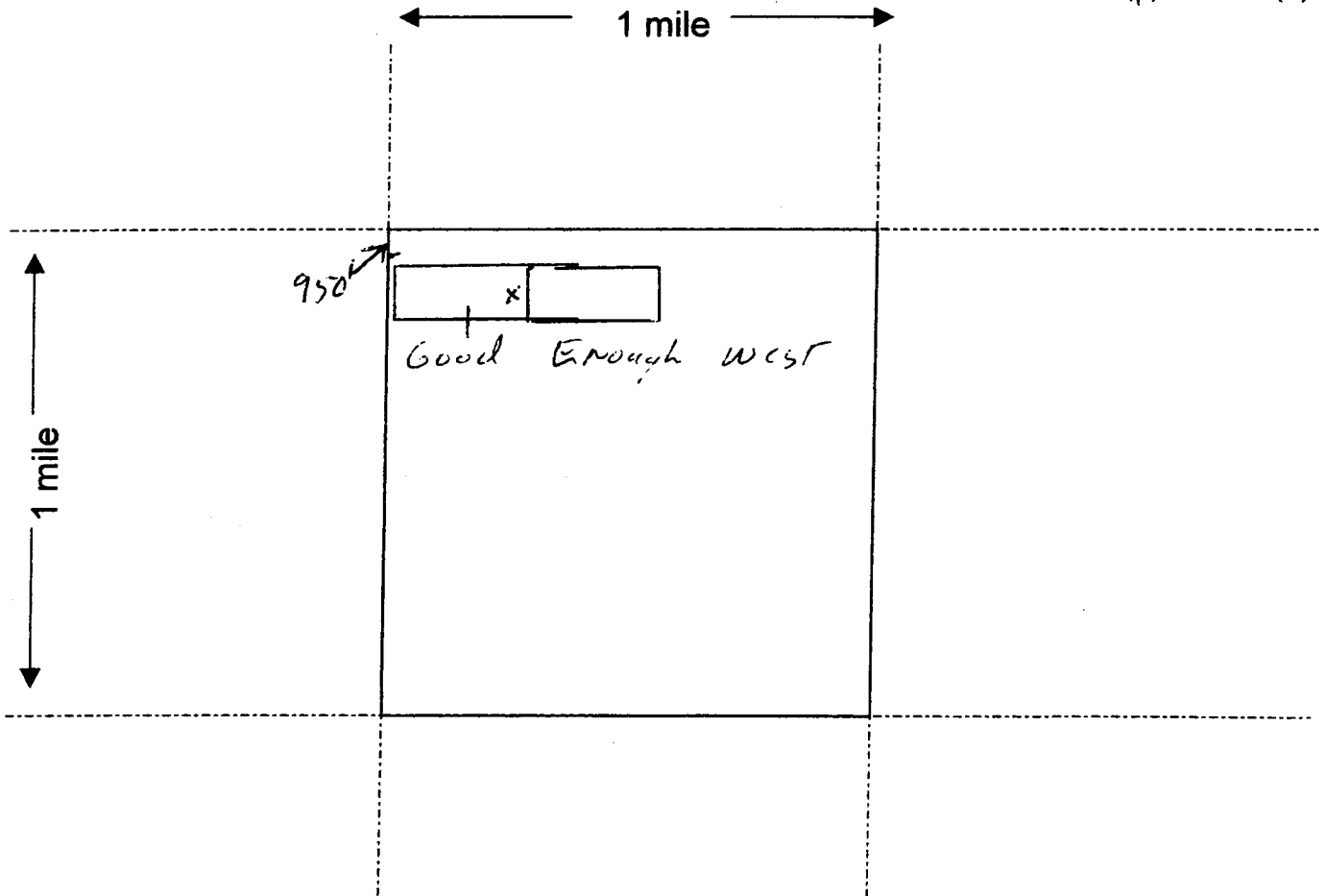

Scale : 1" = 2000 feet



1. The above map depicts the Good Enough W mining claim, which is located in Section (s) 31, Township 20 South, Range 10 East, Gila and Salt River Base and Meridian, Pima County, Arizona.
2. The type of corner and location monuments used are as follows: 2x2 wood
3. The bearings and distances in degrees and feet between claim corners are as depicted on the map.

Form MCF100a
Revised July 2005

This form is available from the Arizona Department of Mines & Mineral Resources and may be reproduced.

010002 01-10-01

F. ANN RODRIGUEZ, RECORDER
RECORDED BY: JCC
DEPUTY RECORDER
0305 PE6-4351



DOCKET: 13916
PAGE: 931
NO. OF PAGES: 2
SEQUENCE: 20102000380
10/18/2010
LOCATN 16:05
MAIL
AMOUNT PAID \$ 10.00

W
KEITH BOWEN
PO BOX 18275
TUCSON AZ 85731

LOCATION NOTICE FOR LODE MINING CLAIM

NOTICE IS HEREBY GIVEN that the NY1-10
_____ lode mining claim has been located
by Charles R Bowen whose current mailing
address is 2739 Julie Lane
Yuma, AZ 85365

BLM
Date
Stamp
PHOENIX, AZ
2010 NOV 17 A 11:52
RECEIVED
BLM AZ STATE OFFICE

The general course of this claim is East / West and it is situated in Pima
County, Arizona. This claim is 1200 feet in length and 600 feet in width. This claim runs
from the location monument on which this location notice is posted approximately 1190 feet in a
West direction to the West end line and 10 feet in a East direction to the
East end line. This claim is marked by six monuments, one at each corner and one at the center of each
end line of the claim.

The location monument on which this notice is posted is situated within Section 5, Township 21
South, Range 10 East, Gila Salt River Base and Meridian, Arizona and this claim encompasses portions
of the following quarter section (s), section (s), Township (s) and Range (s) NE 1/4 + SE 1/4, Sect 5
T 21 S, R 10 E

Gila Salt River Base and Meridian, Arizona.

The locality of this claim with reference to some natural object or permanent monument and additional information
(if any) concerning its locality are as follows: The SW claim corner is approx.
2710' North and 1545' West of the SW corner of
sect 4, T 21 S, R 10 E

DATED AND POSTED on the ground this 28 day of Sept, 20 10

LOCATOR (s) Keith H. Bowen For Charles R Bowen

Form MCF100
Revised July 2005

AMC 403008

401-10 2201-1

MINING CLAIM MAP

Lode (X) Placer ()

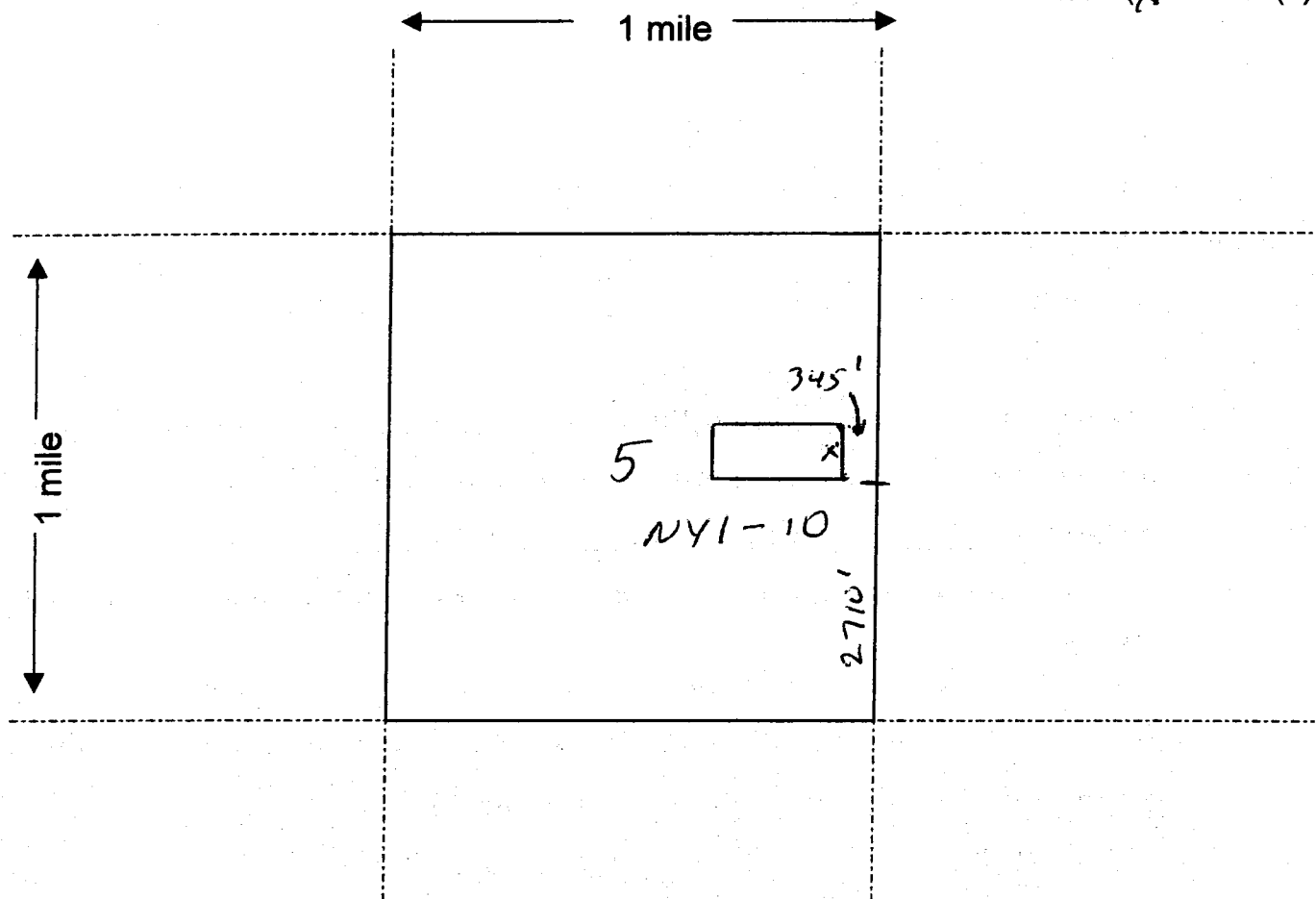

Scale : 1" = 2000 feet



1. The above map depicts the NY1-10 mining claim, which is located in Section (s) 5, Township 21 South, Range 10 East, Gila and Salt River Base and Meridian, Pima County, Arizona.
2. The type of corner and location monuments used are as follows: 2x2 wood
3. The bearings and distances in degrees and feet between claim corners are as depicted on the map.

Form MCF100a
Revised July 2005

ARIZONA DEPARTMENT OF MINES & MINERAL RESOURCES

F. ANN RODRIGUEZ, ~~RECORDER~~
RECORDED BY: JCC
DEPUTY RECORDER
0305 PE6-4351



DOCKET 13916
PAGE 947
NO. OF PAGES: 2
SEQUENCE: 20102000388
10/18/2010
LOCATN 16:05
MAIL
AMOUNT PAID \$ 10.00

W
KEITH BOWEN
PO BOX 18275
TUCSON AZ 85731

LOCATION NOTICE FOR LODE MINING CLAIM

NOTICE IS HEREBY GIVEN that the NYI-20
_____ lode mining claim has been located
by Charles R Bowen whose current mailing
address is 2739 Julie Lane
Yuma, AZ 85365

RECEIVED
BLM AZ STATE OFFICE
2010 NOV 17 A 11:52
PHOENIX, AZ
BLM
Date
Stamp

The general course of this claim is East / West and it is situated in Pima
County, Arizona. This claim is 1500 feet in length and 600 feet in width. This claim runs
from the location monument on which this location notice is posted approximately 1490 feet in a
West direction to the West end line and 10 feet in a East direction to the
East end line. This claim is marked by six monuments, one at each corner and one at the center of each
end line of the claim.

The location monument on which this notice is posted is situated within Section 5, Township 21
South, Range 10 East, Gila Salt River Base and Meridian, Arizona and this claim encompasses portions
of the following quarter section (s), section (s), Township (s) and Range (s) SW 1/4 + SE 1/4 Sect 5,
T21S, R10E

Gila Salt River Base and Meridian, Arizona.

The locality of this claim with reference to some natural object or permanent monument and additional information
(if any) concerning its locality are as follows: The SW claim corner is approx
2110' north and 3045' west of the SW corner
of Sect 4, T21S, R10E

DATED AND POSTED on the ground this 5 day of OCT, 2010

LOCATOR (s) Keith H. Bowen For Charles R Bowen

Form MCF100
Revised July 2005

AMC 403001
-10-10 2010

MINING CLAIM MAP

Lode (✓) Placer ()

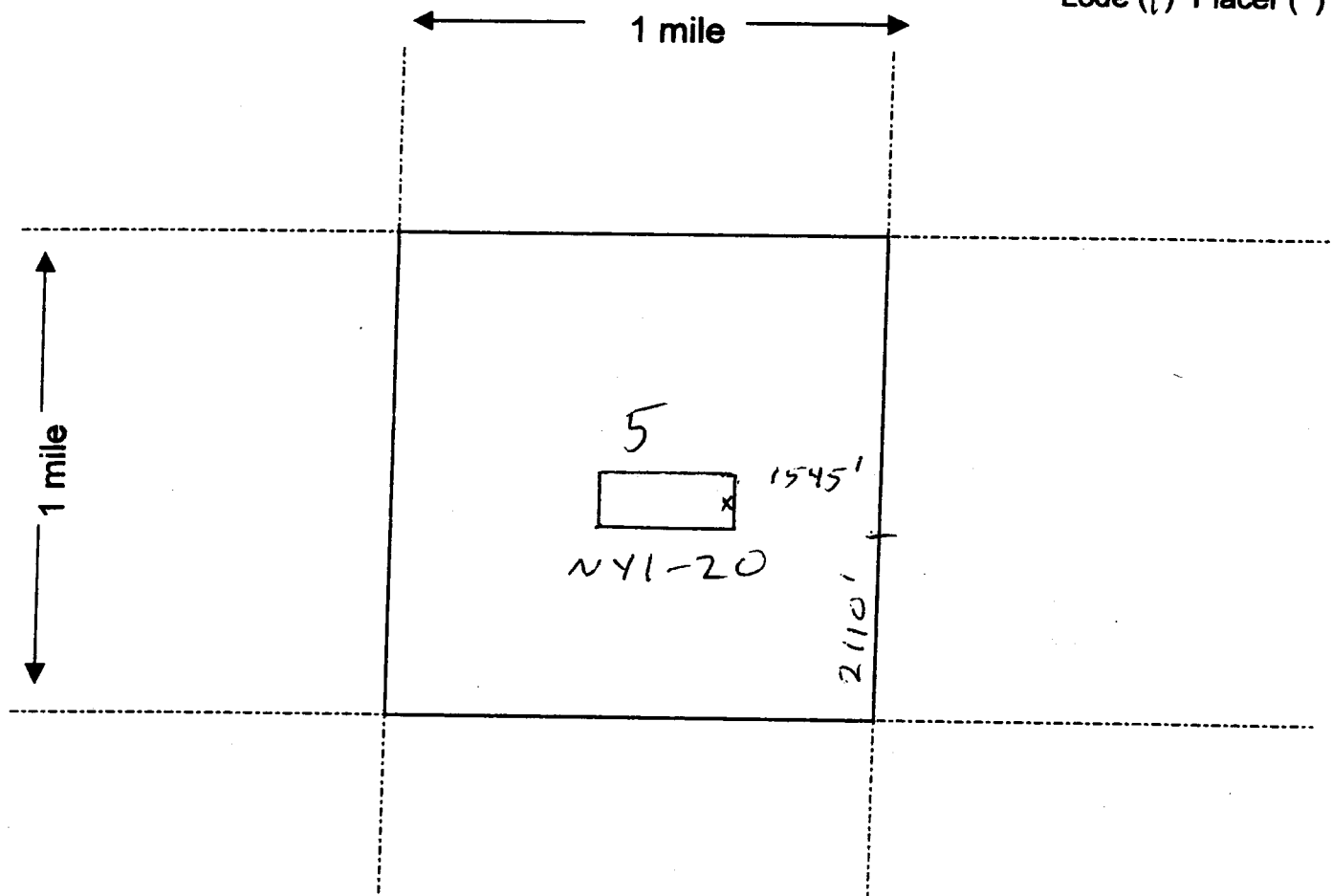

Scale : 1" = 2000 feet



1. The above map depicts the NY1-20 mining claim, which is located in Section (s) 5, Township 21 South, Range 10 East, Gila and Salt River Base and Meridian, Pima County, Arizona.

2. The type of corner and location monuments used are as follows: 2x2 wood

3. The bearings and distances in degrees and feet between claim corners are as depicted on the map.

Form MCF100a
Revised July 2005

This form is available from the Arizona Department of Mines & Mineral Resources and may be reproduced.

MDS-100-100-100

F. ANN RODRIGUEZ, **RECORDER**
RECORDED BY: JCC
DEPUTY RECORDER
0305 PE6-4351



DOCK: 13916
PAGE: 951
NO. OF PAGES: 2
SEQUENCE: 20102000390
LOCATN: 10/18/2010 16:05
MAIL
AMOUNT PAID \$ 10.00

W
KEITH BOWEN
PO BOX 18275
TUCSON AZ 85731

LOCATION NOTICE FOR LODE MINING CLAIM

NOTICE IS HEREBY GIVEN that the NY1-25
lode mining claim has been located
by Charles R Bowen whose current mailing
address is 2739 Julie Lane
Yuma, AZ 85365

RECEIVED
BLM AZ STATE OFFICE
2010 NOV 17 A 11:52
PHOENIX, AZ
BLM
Date
Stamp

The general course of this claim is East / West and it is situated in Pima
County, Arizona. This claim is 1500 feet in length and 600 feet in width. This claim runs
from the location monument on which this location notice is posted approximately 1490 feet in a
West direction to the West end line and 10 feet in a East direction to the
East end line. This claim is marked by six monuments, one at each corner and one at the center of each
end line of the claim.

The location monument on which this notice is posted is situated within Section 5, Township 21
South, Range 10 East, Gila Salt River Base and Meridian, Arizona and this claim encompasses portions
of the following quarter section (s), section (s), Township (s) and Range (s) SW 1/4 Sect 5,
T21S, R10E

Gila Salt River Base and Meridian, Arizona.

The locality of this claim with reference to some natural object or permanent monument and additional information
(if any) concerning its locality are as follows: the SW claim corner is approx
2110' north and 4545' west of the SW corner of
sect 4, T21S, R10E

DATED AND POSTED on the ground this 5 day of Oct, 2010.

LOCATOR (s) Keith H. Bowen For Charles R Bowen

Form MCF100
Revised July 2005

AMC 403002

40-10 2010-10

2

MINING CLAIM MAP

Lode (X) Placer ()

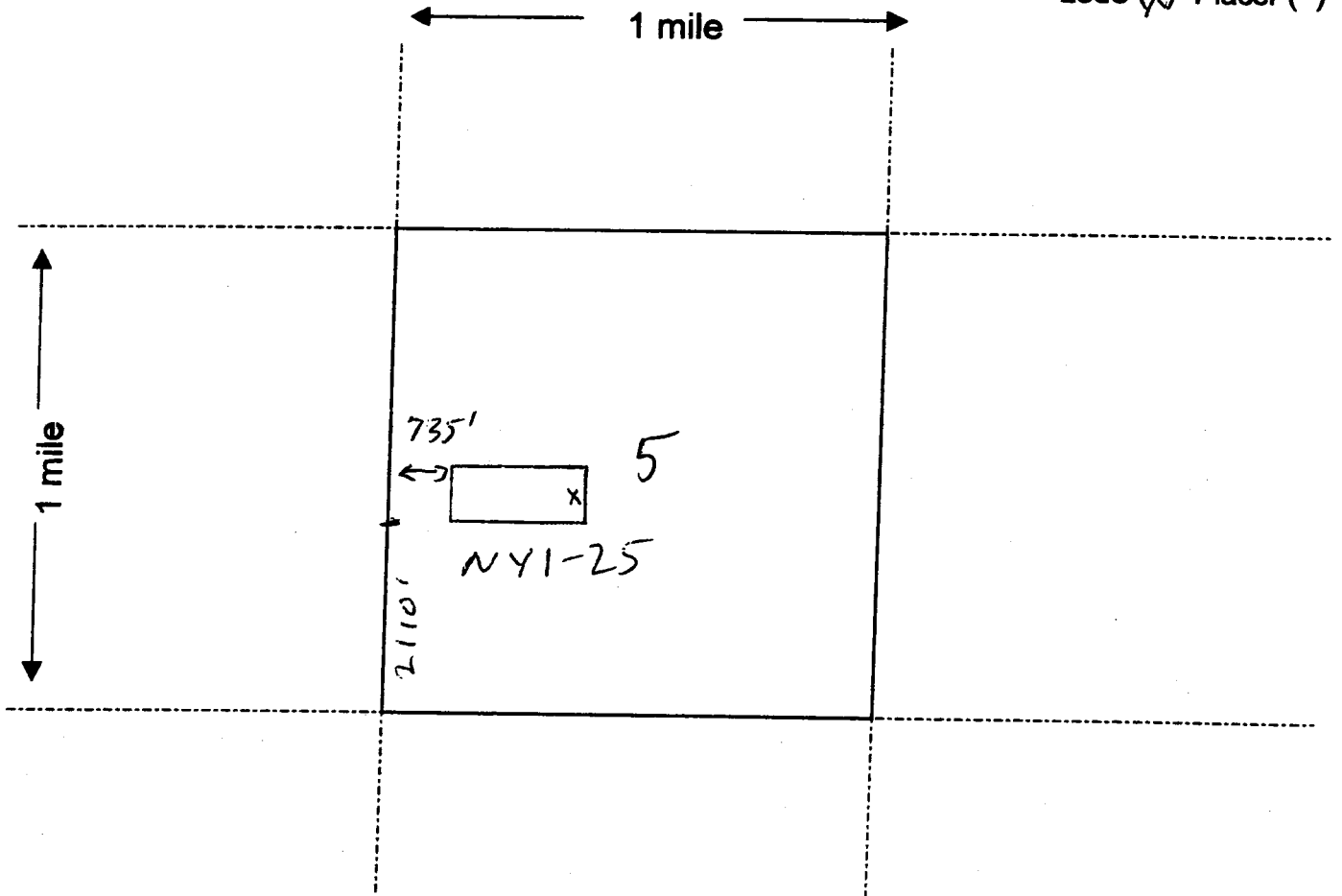

Scale : 1" = 2000 feet



1. The above map depicts the NY1-25 mining claim, which is located in Section (s) 5, Township 21 South, Range 10 East, Gila and Salt River Base and Meridian, Pima County, Arizona.
2. The type of corner and location monuments used are as follows: 2x2 wood
3. The bearings and distances in degrees and feet between claim corners are as depicted on the map.

Form MCF100a
Revised July 2005

This form is available from the Arizona Department of Mines & Mineral Resources and may be reproduced.

ARIZONA DEPARTMENT OF MINES & MINERAL RESOURCES

F. ANN RODRIGUEZ ORDER
RECORDED BY: JCC
DEPUTY RECORDER
0305 PE6-4351



D T: 13916
P 953
NO. OF PAGES: 2
SEQUENCE: 20102000391
10/18/2010
LOCATN 16:05
MAIL
AMOUNT PAID \$ 10.00

W
KEITH BOWEN
PO BOX 18275
TUCSON AZ 85731

LOCATION NOTICE FOR LODE MINING CLAIM

NOTICE IS HEREBY GIVEN that the NY1-26
_____ lode mining claim has been located
by Charles R Bowen whose current mailing
address is 2739 Julie Lane
Yuma, AZ 85365

RECEIVED
BLM AZ STATE OFFICE
2010 NOV 17 A 11:52
PHOENIX, AZ
BLM
Date
Stamp

The general course of this claim is East / West and it is situated in Pima
County, Arizona. This claim is 1500 feet in length and 600 feet in width. This claim runs
from the location monument on which this location notice is posted approximately 1490 feet in a
West direction to the West end line and 10 feet in a East direction to the
East end line. This claim is marked by six monuments, one at each corner and one at the center of each
end line of the claim.

The location monument on which this notice is posted is situated within Section 5, Township 21
South, Range 10 East, Gila Salt River Base and Meridian, Arizona and this claim encompasses portions
of the following quarter section (s), section (s), Township (s) and Range (s) SW 1/4 Sect 5,
T21S, R10E

Gila Salt River Base and Meridian, Arizona.

The locality of this claim with reference to some natural object or permanent monument and additional information
(if any) concerning its locality are as follows: The SW claim corner is approx
1510' north and 4545' west of the SW corner of
sect 4, T21S, R10E

DATED AND POSTED on the ground this 5 day of Oct, 20 10.

LOCATOR (s) Keith H. Bowen For Charles R Bowen

Form MCF100
Revised July 2005

AMC 403003

40-10 BROWN

MINING CLAIM MAP

Lode (x) Placer ()

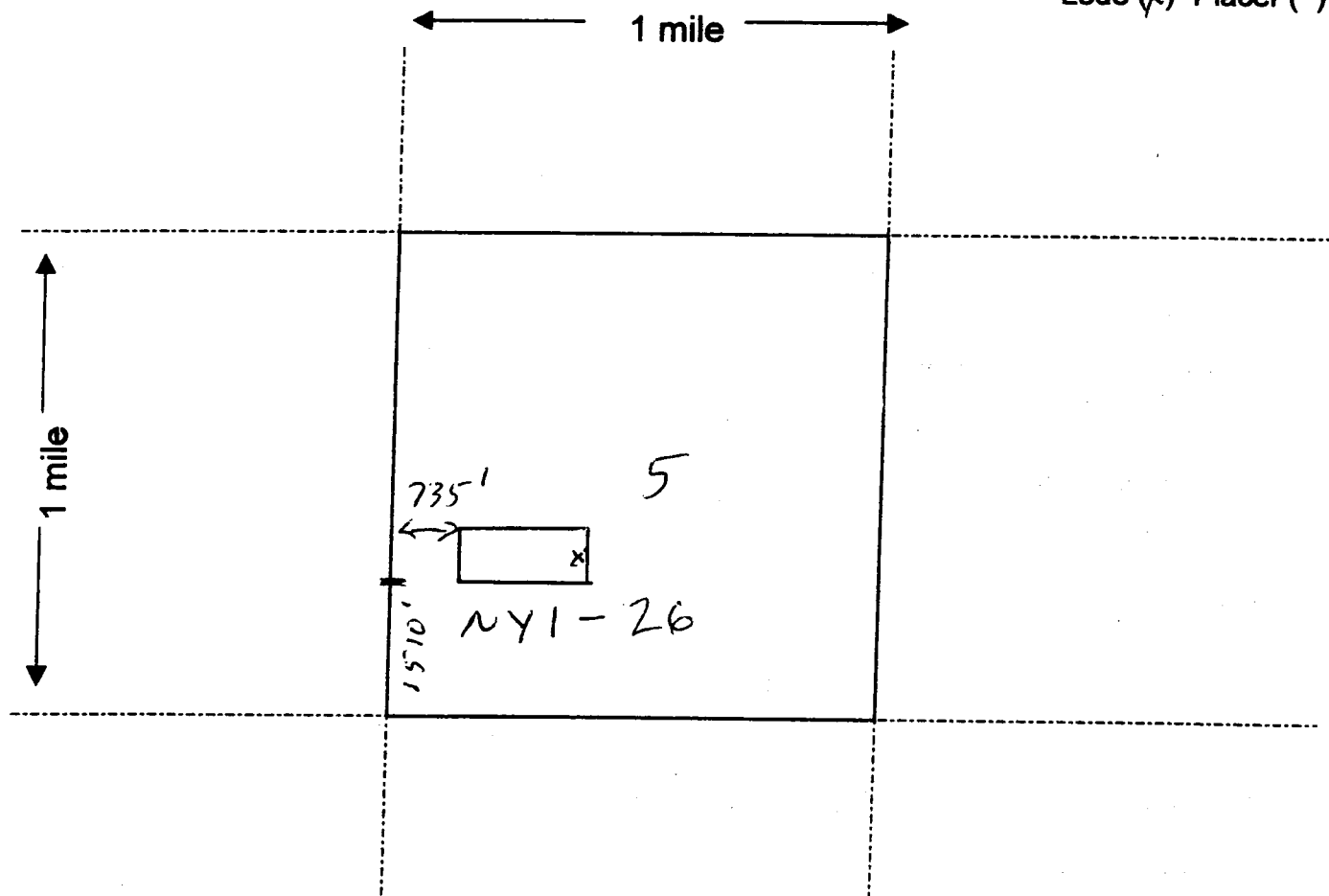

Scale : 1" = 2000 feet



1. The above map depicts the NYI-26 mining claim, which is located in Section (s) 5, Township 21 South, Range 10 East, Gila and Salt River Base and Meridian, Pima County, Arizona.
2. The type of corner and location monuments used are as follows: 2x2 wood
3. The bearings and distances in degrees and feet between claim corners are as depicted on the map.

Form MCF100a
Revised July 2005

This form is available from the Arizona Department of Mines & Mineral Resources and may be reproduced.

ARIZONA DEPARTMENT OF MINES & MINERAL RESOURCES

F. ANN RODRIGUEZ, RECORDER
RECORDED BY: JCC
DEPUTY RECORDER
0305 PE6-4351



DOC# 13916
PAGE# 955
NO. OF PAGES: 2
SEQUENCE: 20102000392
10/18/2010
LOCATN 16:05
MAIL
AMOUNT PAID \$ 10.00

W
KEITH BOWEN
PO BOX 18275
TUCSON AZ 85731

LOCATION NOTICE FOR LODE MINING CLAIM

NOTICE IS HEREBY GIVEN that the NY1-27
_____ lode mining claim has been located
by Charles R Bowen whose current mailing
address is 2739 Julie Lane
Yuma, AZ 85365

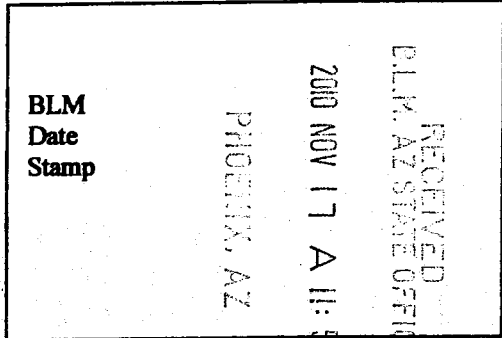

The general course of this claim is East / West and it is situated in Pima
County, Arizona. This claim is 1500 feet in length and 600 feet in width. This claim runs
from the location monument on which this location notice is posted approximately 10 feet in a
West direction to the West end line and 1490 feet in a East direction to the
East end line. This claim is marked by six monuments, one at each corner and one at the center of each
end line of the claim.

The location monument on which this notice is posted is situated within Section 6, Township 21
South, Range 10 East, Gila Salt River Base and Meridian, Arizona and this claim encompasses portions
of the following quarter section (s), section (s), Township (s) and Range (s) SE 1/4 Sect 6 &
SW 1/4 Sect 5, T21S, R10E

Gila Salt River Base and Meridian, Arizona.

The locality of this claim with reference to some natural object or permanent monument and additional information
(if any) concerning its locality are as follows: the SW Claim Corner is approx
2110' North and 6045' West of the SW corner of
sect 4, T21S, R10E

DATED AND POSTED on the ground this 5 day of Oct, 2010

LOCATOR (s) Keith H. Bowen For Charles R Bowen

AMC 403004

403004

Form MCF100
Revised July 2005

MINING CLAIM MAP

Lode (x) Placer ()

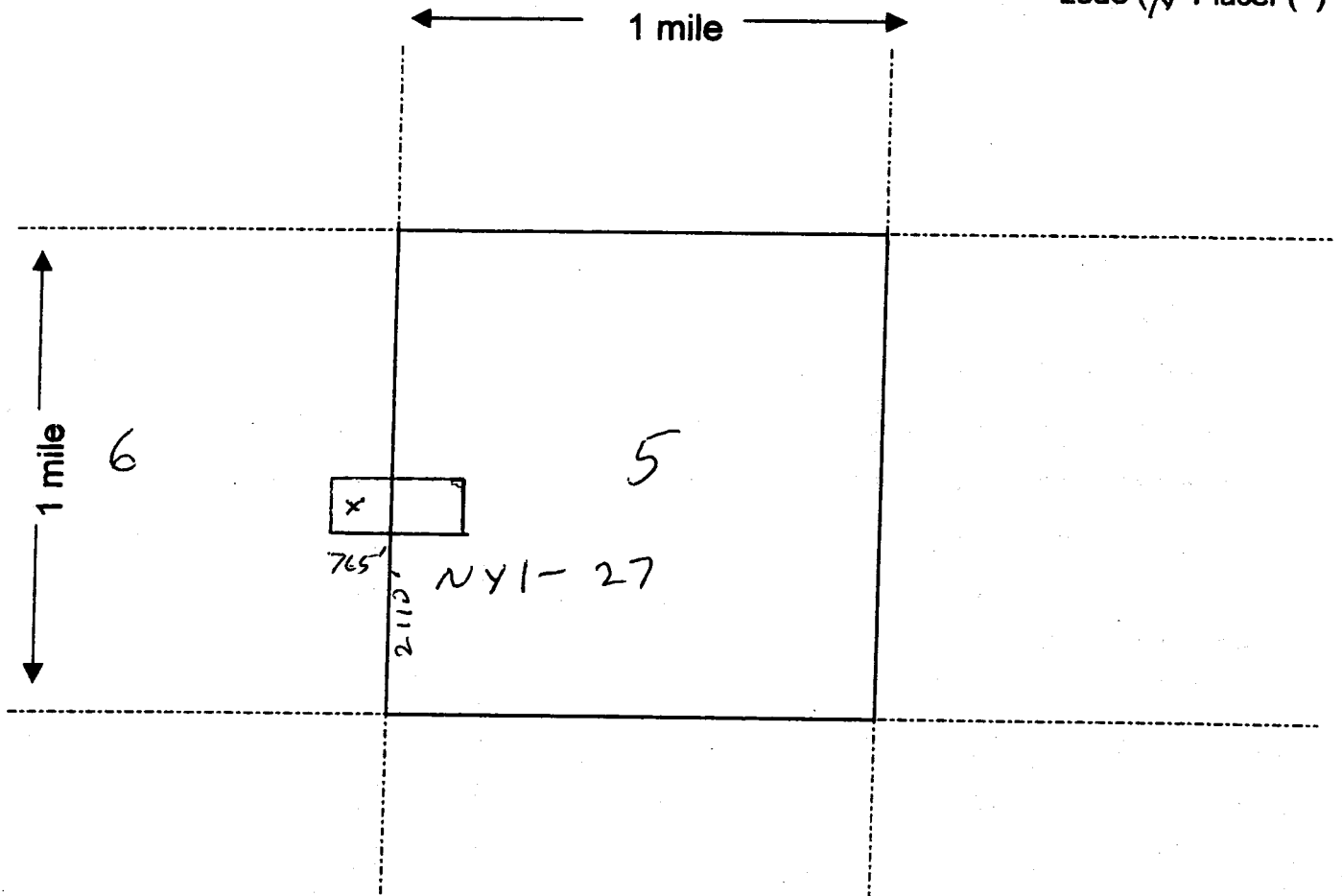

Scale : 1" = 2000 feet



1. The above map depicts the NY1-27 mining claim, which is located in Section (s) 5 & 6, Township 21 South, Range 10 East, Gila and Salt River Base and Meridian, Pima County, Arizona.
2. The type of corner and location monuments used are as follows: 2x2 wood
3. The bearings and distances in degrees and feet between claim corners are as depicted on the map.

Form MCF100a
Revised July 2005

This form is available from the Arizona Department of Mines & Mineral Resources and may be reproduced.

ARIZONA DEPARTMENT OF MINES & MINERAL RESOURCES

F. ANN RODRIGUEZ, ORDER
RECORDED BY: JCC
DEPUTY RECORDER
0305 PE6-4351

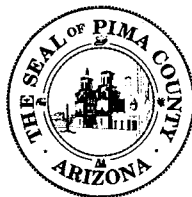

DOCS: 13916
PA: 957
NO. OF PAGES: 2
SEQUENCE: 20102000393
10/18/2010
LOCATN: 16:05
MAIL
AMOUNT PAID \$ 10.00

W
KEITH BOWEN
PO BOX 18275
TUCSON AZ 85731

LOCATION NOTICE FOR LODE MINING CLAIM

NOTICE IS HEREBY GIVEN that the NY1-28
_____ lode mining claim has been located
by Charles R Bowen whose current mailing
address is 2739 Julie Lane
Yuma, AZ 85365

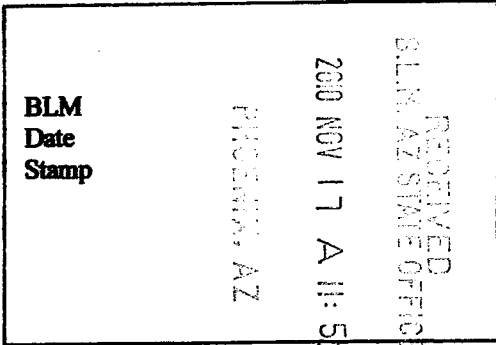

The general course of this claim is East / West and it is situated in Pima
County, Arizona. This claim is 1500 feet in length and 600 feet in width. This claim runs
from the location monument on which this location notice is posted approximately 10 feet in a
West direction to the West end line and 1490 feet in a East direction to the
East end line. This claim is marked by six monuments, one at each corner and one at the center of each
end line of the claim.

The location monument on which this notice is posted is situated within Section 6, Township 21
South, Range 10 East, Gila Salt River Base and Meridian, Arizona and this claim encompasses portions
of the following quarter section (s), section (s), Township (s) and Range (s) SE 1/4 Sect 6, SW 1/4 Sect
T21S, R10E

Gila Salt River Base and Meridian, Arizona.

The locality of this claim with reference to some natural object or permanent monument and additional information
(if any) concerning its locality are as follows: The SW claim corner is approx
1510' North and 6045' west of the SW corner of
sect 4, T21S, R10E

DATED AND POSTED on the ground this 5 day of Oct, 2010.

LOCATOR (s) Keith H. Bowen For Charles R Bowen

Form MCF100
Revised July 2005

AMC 4030051

100-10 02001

MINING CLAIM MAP

Lode (X) Placer ()

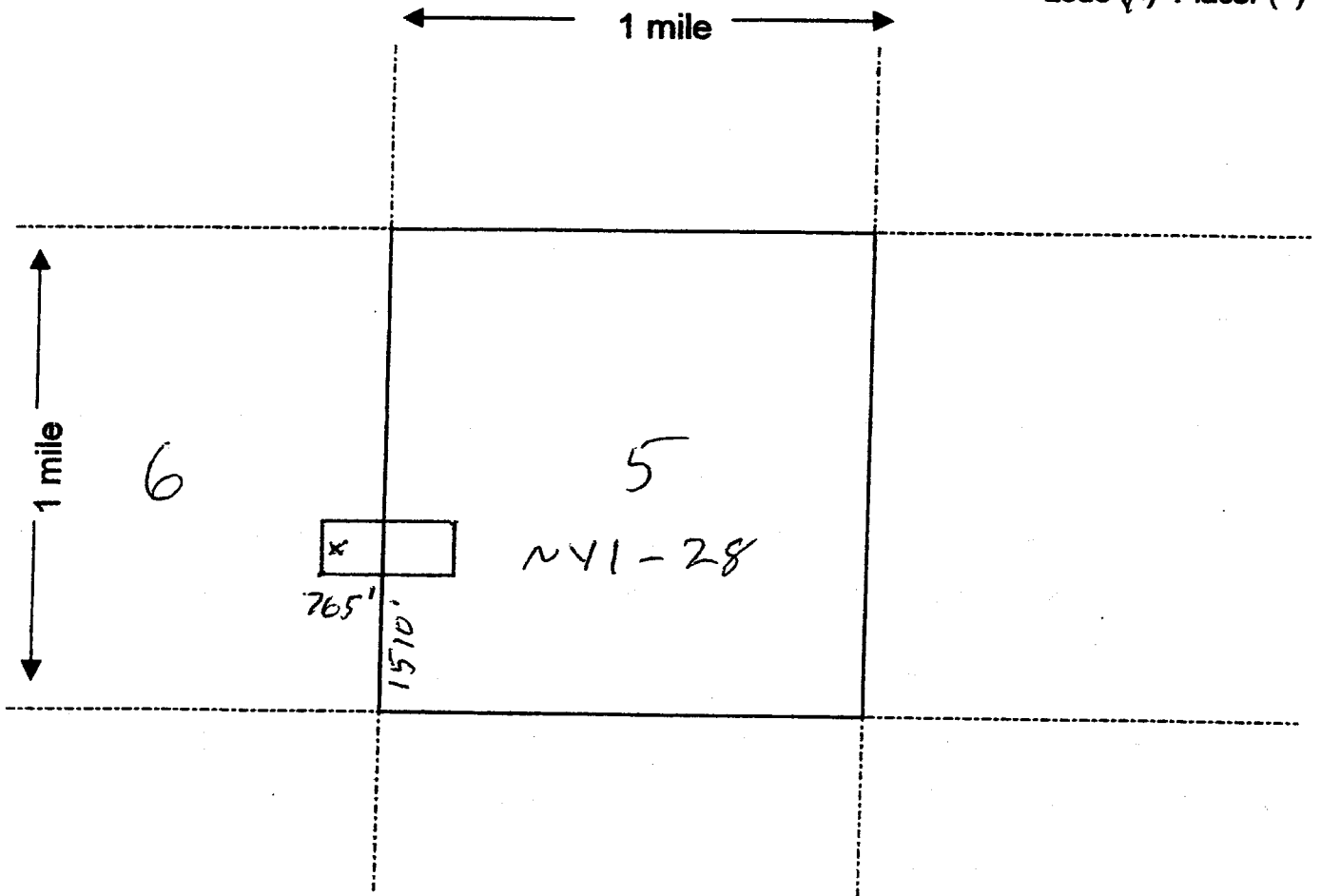

Scale : 1" = 2000 feet



1. The above map depicts the NY1-28 mining claim, which is located in Section (s) 5 & 6, Township 21 South, Range 10 East, Gila and Salt River Base and Meridian, Pima County, Arizona.

2. The type of corner and location monuments used are as follows: 2x2 wood

3. The bearings and distances in degrees and feet between claim corners are as depicted on the map.

Form MCF100a
Revised July 2005

This form is available from the Arizona Department of Mines & Mineral Resources and may be reproduced.

1-10-10 201010

F. ANN RODRIGUEZ, ORDER
RECORDED BY: JCC
DEPUTY RECORDER
0305 PE6-4351



DO : 13916
PA: 959
NO. OF PAGES: 2
SEQUENCE: 20102000394
10/18/2010
LOCATN: 16:05
MAIL
AMOUNT PAID \$ 10.00

W
KEITH BOWEN
PO BOX 18275
TUCSON AZ 85731

LOCATION NOTICE FOR LODE MINING CLAIM

NOTICE IS HEREBY GIVEN that the NY1-29
_____ lode mining claim has been located
by Charles R Bowen whose current mailing
address is 2739 Julie Lane
Yuma, AZ 85365

RECEIVED
BLM, AZ STATE OFFICE
2010 NOV 17 A 11:52
PHOENIX, AZ
BLM
Date
Stamp

The general course of this claim is East / West and it is situated in Pima
County, Arizona. This claim is 1500 feet in length and 600 feet in width. This claim runs
from the location monument on which this location notice is posted approximately 10 feet in a
West direction to the West end line and 1490 feet in a East direction to the
East end line. This claim is marked by six monuments, one at each corner and one at the center of each
end line of the claim.

The location monument on which this notice is posted is situated within Section 6, Township 21
South, Range 10 East, Gila Salt River Base and Meridian, Arizona and this claim encompasses portions
of the following quarter section (s), section (s), Township (s) and Range (s) S.E 1/4 Sect 6 &
SW 1/4 Sect 5, T21S, R10E
Gila Salt River Base and Meridian, Arizona.

The locality of this claim with reference to some natural object or permanent monument and additional information
(if any) concerning its locality are as follows: The SW Claim Corner is Approx
910' North and 6045' West of the SW corner of
sect 4, T21S, R10E

DATED AND POSTED on the ground this 5 day of Oct, 2010.
LOCATOR (s) Keith H. Bowen For Charles R Bowen

Form MCF100
Revised July 2005

AMC 403006

10-10 2010

MINING CLAIM MAP

Lode (X) Placer ()

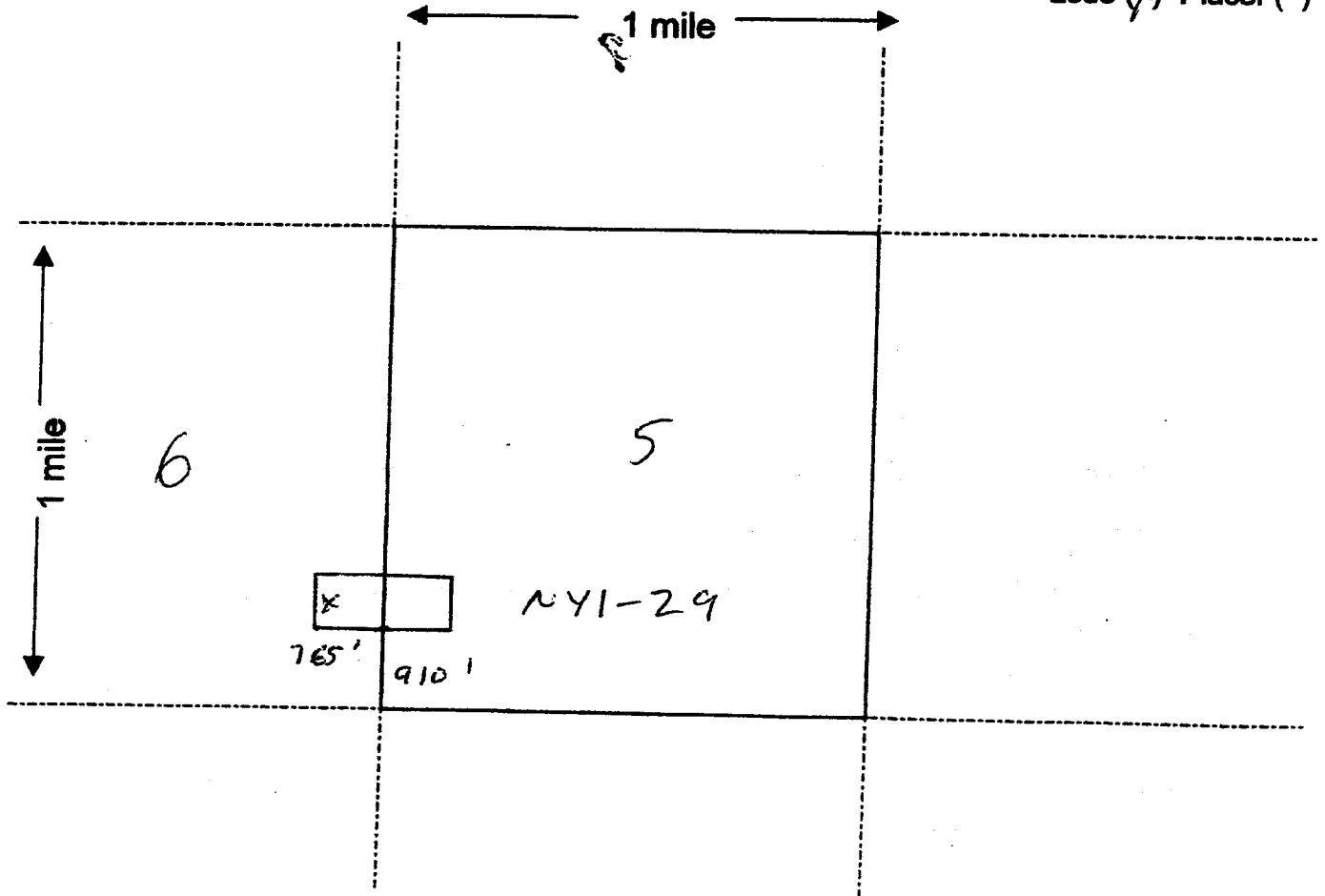

Scale : 1" = 2000 feet



1. The above map depicts the NY1-29 mining claim, which is located in Section (s) 5 + 6, Township 21 South, Range 10 East, Gila and Salt River Base and Meridian, Pima County, Arizona.
2. The type of corner and location monuments used are as follows: 2x2 wood
3. The bearings and distances in degrees and feet between claim corners are as depicted on the map.

Form MCF100a
Revised July 2005

This form is available from the Arizona Department of Mines & Mineral Resources and may be reproduced.

1-10-10 2005

F. ANN RODRIGUEZ, RECORDER
RECORDED BY: JCC
DEPUTY RECORDER
0305 PE6-4351



DOCKET: 13916
PAGE: 961
NO. PAGES: 2
SEQUENCE: 20102000395
10/18/2010
LOCATN 16:05
MAIL
AMOUNT PAID \$ 10.00

W
KEITH BOWEN
PO BOX 18275
TUCSON AZ 85731

LOCATION NOTICE FOR LODE MINING CLAIM

NOTICE IS HEREBY GIVEN that the NY1-35
_____ lode mining claim has been located
by Charles R Bowen whose current mailing
address is 2739 Julie Lane
Yuma, AZ 85365

RECEIVED
BLM AZ STATE OFFICE
2010 NOV 17 A 11:52
PHOENIX, AZ
BLM
Date
Stamp

The general course of this claim is East / West and it is situated in Pima
County, Arizona. This claim is 1500 feet in length and 600 feet in width. This claim runs
from the location monument on which this location notice is posted approximately 10 feet in a
West direction to the West end line and 1490 feet in a East direction to the
East end line. This claim is marked by six monuments, one at each corner and one at the center of each
end line of the claim.

The location monument on which this notice is posted is situated within Section 5, Township 21
South, Range 10 East, Gila Salt River Base and Meridian, Arizona and this claim encompasses portions
of the following quarter section (s), section (s), Township (s) and Range (s) SW 1/4 Sect 5,
T 21 S, R 10 E

Gila Salt River Base and Meridian, Arizona.

The locality of this claim with reference to some natural object or permanent monument and additional information
(if any) concerning its locality are as follows: the SW claim corner is approx
910' north and 4545' west of the SW corner of
sect 4, T 21 S, R 10 E

DATED AND POSTED on the ground this 5 day of Oct, 2010.

LOCATOR (s) Keith H. Bowen For Charles R Bowen

Form MCF100
Revised July 2005

AMC 403007

11-10-10

2

MINING CLAIM MAP

Lode (X) Placer ()

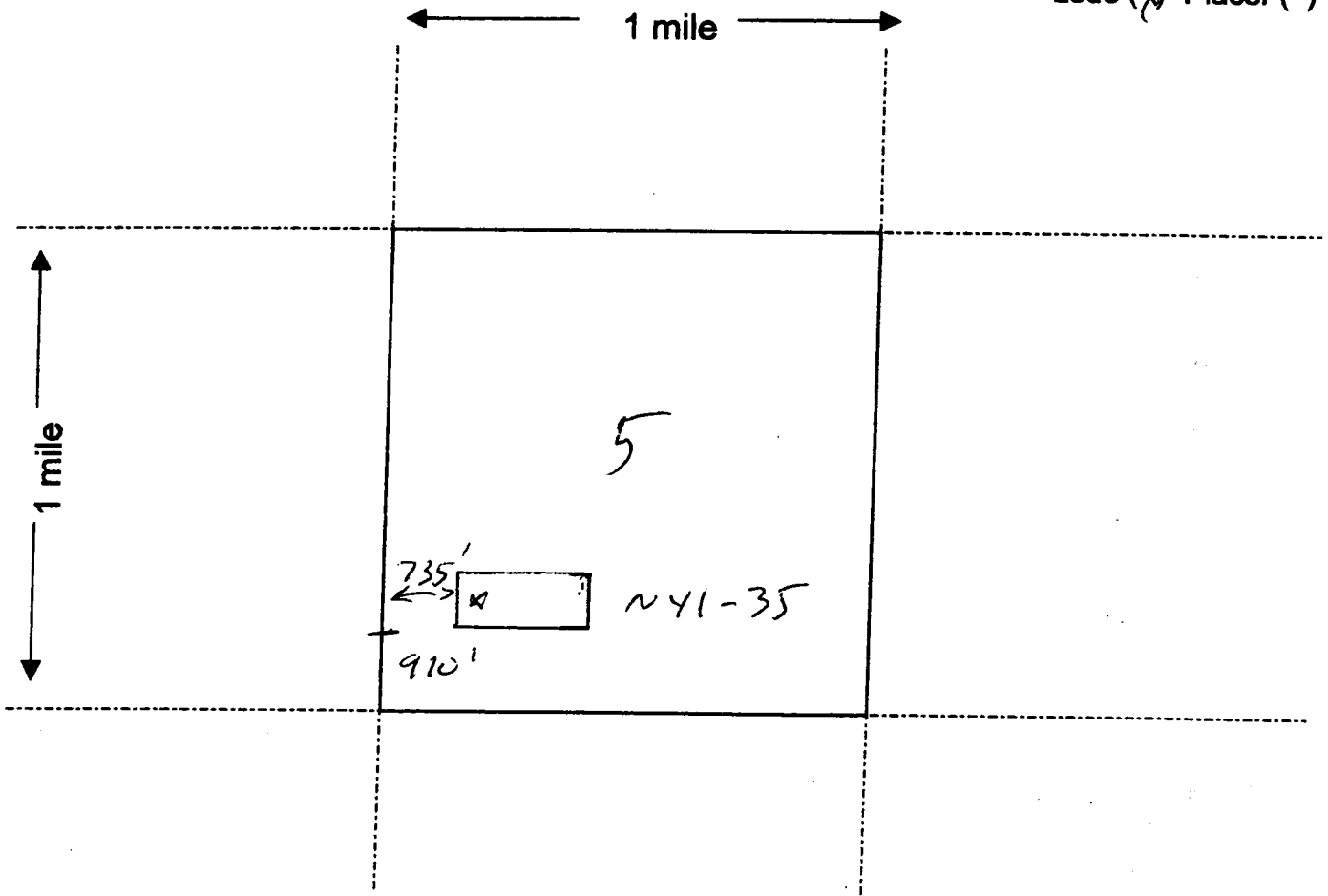

Scale : 1" = 2000 feet



1. The above map depicts the NY1-35 mining claim, which is located in Section (s) 5, Township 21 South, Range 10 East, Gila and Salt River Base and Meridian, Pima County, Arizona.
2. The type of corner and location monuments used are as follows: 2x2 wood
3. The bearings and distances in degrees and feet between claim corners are as depicted on the map.

Form MCF100a
Revised July 2005

This form is available from the Arizona Department of Mines & Mineral Resources and may be reproduced.

ARIZONA DEPARTMENT OF MINES & MINERAL RESOURCES

RUN TIME: 11:52 AM

UNITED STATES DEPARTMENT OF INTERIOR
BUREAU OF LAND MANAGEMENT
GEOGRAPHIC REPORT WITH LAND
Sorted by Meridian Township Range

RUN DATE: 11/17/2010
Page 1 of 1

Adm State: AZ

Serial Number: AZA 02370005
Total Case Acres: 89,883.340

<u>Casetype</u>	<u>Case Disp</u>				<u>Sect</u>	<u>Sur Typ</u>	<u>Sur Num</u>	<u>Suff</u>	<u>Subdivision</u>	<u>Act Pend</u>
221005	AUTHORIZED	14	0210S	0100E	006	LOTS			4-7;	

Input Parameters for Geographic Report with Land

System Id = CR

Admin State = AZ

Geo State =

Casetype Begins With

Case Disp Txt = AUTHORIZED, CANCELLED, EXPIRED, PENDING, REJECTED, RELINQUISHED, VOID, WITHDRAWN

Mer Twp Rng =

Section =

Mtrs = 14 0200S 0100E 031, 14 0200S 0100E 999, 14 0210S 0100E 005, 14 0210S 0100E 006, 14 0210S 0100E 999

Commodity =

Commodity Txt =

Pending Org =

Pend Org Decode =

Total Rows Returned: 1

